

INSTALLATION INSTRUCTIONS AND SERVICE MANUAL

SEPARATED COMBUSTION GAS-FIRED INDOOR DUCT FURNACE

ATTENTION: READ THIS MANUAL AND ALL LABELS ATTACHED TO THE UNIT CAREFULLY BEFORE ATTEMPTING TO INSTALL, OPERATE OR SERVICE THESE UNITS! CHECK UNIT DATA PLATE FOR TYPE OF GAS AND ELECTRICAL SPECIFICATIONS AND MAKE CERTAIN THAT THESE AGREE WITH THOSE AT POINT OF INSTALLATION. RECORD THE UNIT MODEL AND SERIAL No.(s) IN THE SPACE PROVIDED. RETAIN FOR FUTURE REFERENCE.

Unit No. _____ Serial No. _____

FOR YOUR SAFETY

The use and storage of gasoline or other flammable vapors and liquids in open containers in the vicinity of this appliance is hazardous.



FOR YOUR SAFETY

- If you smell gas:
1. Open windows.
 2. Don't touch electrical switches.
 3. Extinguish any open flame.
 4. Immediately call your gas supplier.

▲ WARNING Improper installation, adjustment, alteration, service or maintenance can cause property damage, injury or death. Read the installation, operating and maintenance instructions thoroughly before installing or servicing this equipment.

APPROVED FOR USE IN CALIFORNIA

▲ WARNING Install, operate and maintain unit in accordance with manufacturer's instructions to avoid exposure to fuel substances or substances from incomplete combustion which can cause death or serious illness. The state of California has determined that these substances may cause cancer, birth defects, or other reproductive harm.

INSTALLER'S RESPONSIBILITY

Installer Please Note: This equipment has been test fired and inspected. It has been shipped free from defects from our factory. However, during shipment and installation, problems such as loose wires, leaks or loose fasteners may occur. **It is the installer's responsibility to inspect and correct any problems that may be found.**

RECEIVING INSTRUCTIONS

Inspect shipment immediately when received to determine if any damage has occurred to the unit during shipment. After the unit has been uncrated, check for any visible damage to the unit. If any damage is found, the consignee should sign the bill of lading indicating such damage and immediately file claim for damage with the transportation company.



MESTEK, INC.

260 NORTH ELM ST., WESTFIELD, MA 01085

TEL: (413) 568-9571 FAX: (413) 562-8437

www.mestek.com



TABLE OF CONTENTS

GENERAL SAFETY INFORMATION SEPARATED COMBUSTION DUCT FURNACE	1,2,3
SPECIFICATIONS	4
PERFORMANCE DATA	5
CLEARANCES	6
INSTALLATION	
Location	6
Ductwork, Air Flow	6,7
Suspension	7,8
Electrical Connections, Wiring Diagrams	8,9,10,11,12
Combustion Air Inlet System Piping	12,13
Exhaust Venting	13,14,15
Gas Piping	16
Pipe Installation	17,18,19
OPERATION	
Explanation of Controls	21
Primary Air Shutter Adjustments	21
Shut Down	21
MAINTENANCE	22
COMPONENT PARTS	20,23
TROUBLESHOOTING CHART	24-28
WARRANTY	29
UNIT NUMBER DESCRIPTION	30
START UP/INSPECTION SHEET	32

GENERAL SAFETY INFORMATION

The duct furnace design is certified by ETL for use with natural and LP (propane) gases. ANSI and NFPA Standards as well as Canadian installation codes referred to in this manual are the ones that were applicable at the time that the design was certified.

If the unit is to be installed at altitudes exceeding 2,000 feet (610m) above sea level, derate the input by 4% for each 1,000 feet (305m) rise above sea level. Special orifices are required for installations above 2,000 feet.

When units are installed in Canada, any reference to derations at altitudes in excess of 2,000 feet (610m) are to be ignored. At altitudes of 2,000 to 4,500 feet (610 to 1372m), the units must be orificed for 90% of normal altitude rating, and be so marked in accordance with ETL certification.

The following terms are used throughout this manual, in addition to the ETL requirements to bring attention to the presence of potential hazards, or to important information concerning the product:

▲ DANGER Indicates an imminently hazardous situation which, if not avoided, will result in death, serious injury, or substantial property damage.

▲ WARNING Indicates an imminently hazardous situation which, if not avoided, could result in death, serious injury, or substantial property damage.

▲ CAUTION Indicates an imminently hazardous situation which, if not avoided, may result in minor injury or property damage.

NOTICE: Used to notify of special instructions on installation, operation, or maintenance which are important to equipment but not related to personal injury.

GENERAL SAFETY INFORMATION

▲ WARNING Failure to comply with the general safety information may result in extensive property damage, severe personal injury, or death!

▲ WARNING This product must be installed by a licensed plumber or gas fitter when installed within the Commonwealth of Massachusetts.

Installation must be in accordance with local codes, or in absence of local codes, with the latest edition of ANSI Standard Z223.1 (N.F.P.A. No. 54) National Fuel Gas Code. All of the ANSI and NFPA Standards referred to in these installation instructions are those that were applicable at the time the design of this appliance was certified. The ANSI Standards are available from the American National Standards Institute, Inc., 11 West 42nd Street, New York, NY 10036 or www.ansi.org. The NFPA Standards are available from the National Fire Protection Association, Batterymarch Park, Quincy, MA 02269. These duct furnaces are designed for use in airplane hangars when installed in accordance with ANSI/NFPA No. 409, and in public garages when installed in accordance with NFPA No. 88A and NFPA No. 88B.

If installed in Canada, the installation must conform with local building codes, or in the absence of local building codes, with CSA-B149.1 "Installation Codes for Natural Gas Burning Appliances and Equipment" or CSA-B149.2 "Installation Codes for Propane Gas Burning Appliances and Equipment." These duct furnaces have been designed and certified to comply with CSA 2.6. Also see sections on installation in AIRCRAFT HANGARS and PUBLIC GARAGES.

▲ WARNING Do not alter the duct furnace in any way, or damage to the unit and/or severe personal injury or death may occur!

▲ WARNING Never service any component without first disconnecting all electrical and gas supplies to the unit, or severe personal injury or death may occur!

▲ CAUTION Ensure that all power sources conform to the requirements of the duct furnace, or damage to the unit will result!

Follow installation instructions CAREFULLY to avoid creating unsafe conditions. All wiring should be done and checked by a qualified electrician, using copper wire only. All external wiring must conform to applicable local codes, and to the latest edition of the National Electric Code, ANSI/NFPA No. 70. All gas connections should be made and leak-tested by a suitably qualified individual, per instructions in this manual.

Also follow procedures listed on the "Gas Equipment Start-Up" sheet located in this manual.

Use only the fuel for which the duct furnace is designed (see rating plate). Using LP gas in a heater that requires natural gas, or vice versa, will create risk of gas leaks, carbon monoxide poisoning, and explosion.

▲ WARNING Do not attempt to convert furnace for use with a fuel other than the one intended. Such conversion is dangerous, as it will create the risks previously listed.

Make certain that the power source conforms to the electrical requirements of the furnace.

▲ WARNING Do not depend upon a thermostat or other switch as sole means of disconnecting power when installing or servicing duct furnace. Always disconnect power at main circuit breaker as described above. Failure to do so could result in electrical shock.

Special attention must be given to any grounding information pertaining to this duct furnace. To prevent the risk of electrocution, the furnace must be securely and adequately grounded. This should be accomplished by connecting a ground conductor between the service panel and the furnace. To ensure a proper ground, the grounding means must be tested by a qualified electrician.

Do not insert fingers or foreign objects into furnace or its air moving device. Do not block or tamper with the heater in any manner while in operation, or just after it has been turned off, as some parts maybe hot enough to cause injury.

This furnace is intended for general heating applications ONLY. It must NOT be used in potentially dangerous locations such as flammable, explosive, chemical-laden, or wet atmospheres.

In cases in which property damage may result from malfunction of the furnace, a back-up system or temperature sensitive alarm should be used.

▲ CAUTION The open end of piping systems being purged shall not discharge into areas where there are sources of ignition or into confined spaces UNLESS precautions are taken as follows: (1) by ventilation of the space, (2) control of the purging rate, (3) elimination of all hazardous conditions. All precautions must be taken to perform this operation in a safe manner!

Unless otherwise specified, the following conversions may be used for calculating SI unit measurements:

1 foot = 0.305 m	1000 BTU/cu. ft. = 37.5 MJ/m ³
1 inch = 25.4 mm	1000 BTU per hour = 0.293 kW
1 gallon = 3.785 L	1 inch water column = 0.249 kPa
1 pound = 0.453kg	liter/second = CFM x 0.472
1 psig = 6.894 kPa	meter/second = FPM ÷ 196.8
1 cubic foot = 0.028m ³	

SPECIFICATIONS

Table 1

Unit Size	A	B	C	D (Dia)*†	Gas Inlet inches		Weight lb. (kg)
	inches (mm)	inches (mm)	inches (mm)	inches (mm)	Nat	LP	
100	17-7/8 (454)	15-1/2 (394)	17-1/8 (435)	4 (102)	1/2	1/2	161 (73)
125	20-5/8 (524)	18-1/4 (464)	19-7/8 (505)	4 (102)	1/2	1/2	180 (82)
150	20-5/8 (524)	18-1/4 (464)	19-7/8 (505)	4 (102)	1/2	1/2	188 (85)
175	23-3/8 (594)	21 (533)	22-5/8 (575)	4 (102)	1/2	1/2	207 (93)
200	26-1/8 (664)	23-3/4 (603)	25-3/8 (645)	5 (127)	1/2	1/2	227 (103)
225	28-7/8 (733)	26-1/2 (673)	28-1/8 (714)	5 (127)	3/4	1/2 or 3/4	246 (116)
250	31-5/8 (803)	29-1/4 (743)	30-7/8 (784)	5 (127)	3/4	1/2 or 3/4	266 (121)
300	37-1/8 (943)	34-3/4 (883)	36-3/8 (924)	6 (152)	3/4	1/2 or 3/4	305 (138)
350	42-5/8 (1083)	40-1/4 (1022)	41-7/8 (1064)	6 (152)	3/4	1/2 or 3/4	344 (156)
400	48-1/8 (1222)	45-3/4 (1162)	47-3/8 (1203)	6 (152)	3/4	1/2 or 3/4	383 (174)

†NOTE: "D" diameter equals the air inlet opening and the flue discharge opening.

Figure 1 - Separated Combustion Duct Furnace

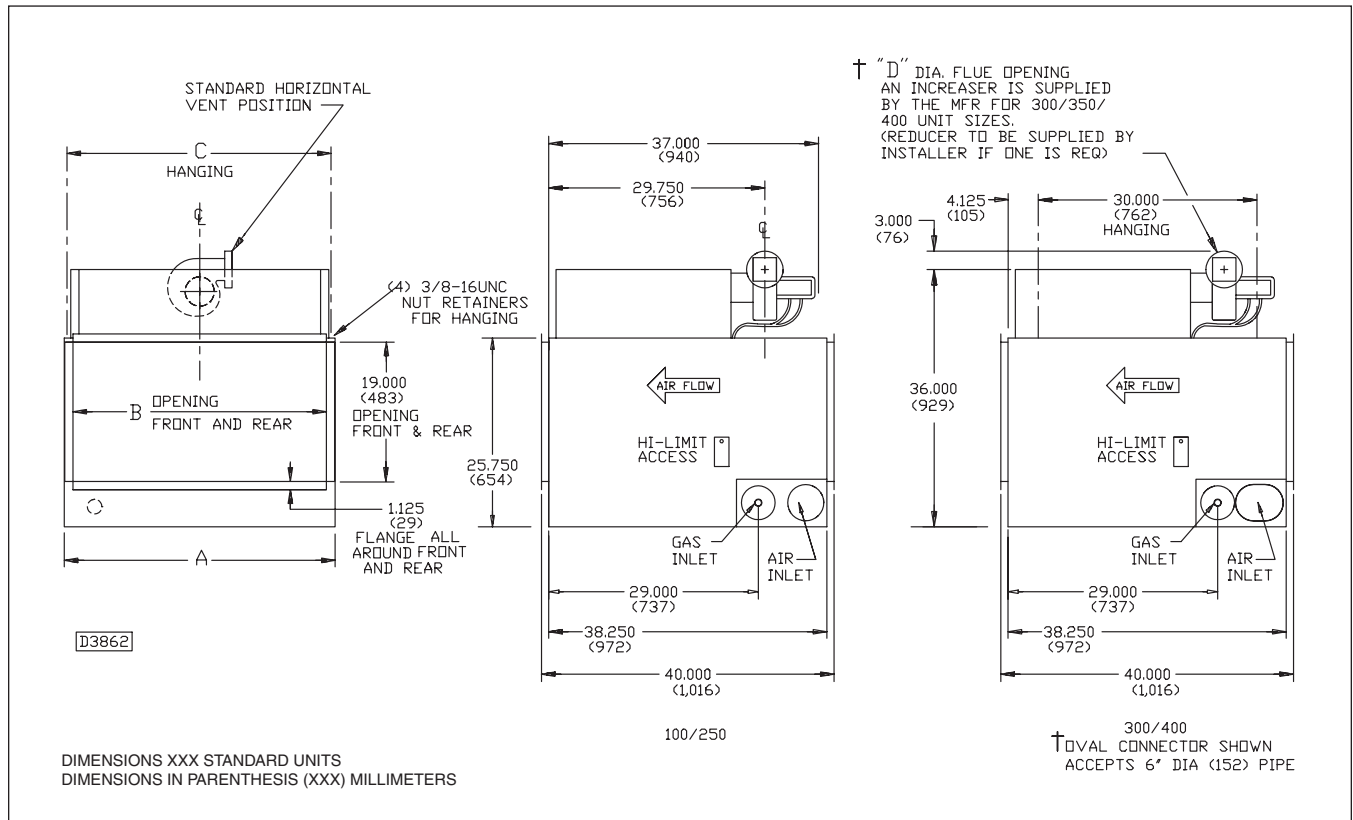

PERFORMANCE DATA

Table 2

UNIT CAPACITY (MBH)	100	125	150	175	200	225	250	300	350	400
MAX. INPUT - MBH	100	125	150	175	200	225	250	300	350	400
(kW)	(29.3)	(36.6)	(43.9)	(51.2)	(58.6)	(65.9)	(73.2)	(87.8)	(102.5)	(117.1)
MIN. INPUT - MBH	50	62.5	75	87.5	100	112.5	125	150	175	200
(kW)	(14.6)	(18.3)	(21.9)	(25.6)	(29.3)	(32.9)	(36.6)	(43.9)	(51.2)	(58.6)
OUTPUT - MBH	80	100	120	140	160	180	200	240	280	320
(kW)	(23.4)	(29.3)	(35.1)	(41.0)	(46.9)	(52.7)	(58.6)	(70.3)	(82.0)	(93.7)
FULL LOAD AMPS @ 115V	1.9	1.9	1.9	1.9	1.9	1.9	1.9	1.9	1.9	1.9
MIN. CIRCUIT AMPS @ 115V	2.3	2.3	2.3	2.3	2.3	2.3	2.3	2.3	2.3	2.3
MINIMUM CFM	822	1,028	1,233	1,439	1,645	1,850	2,056	2,467	2,878	3,289
(m ³ /s)	(0.388)	(0.485)	(0.582)	(0.679)	(0.776)	(0.873)	(0.970)	(1.164)	(1.358)	(1.552)
TEMP RISE - °F	90	90	90	90	90	90	90	90	90	90
(°C)	(50)	(50)	(50)	(50)	(50)	(50)	(50)	(50)	(50)	(50)
PRESSURE DROP - in. WC	0.10	0.09	0.09	0.09	0.09	0.09	0.09	0.10	0.10	0.10
(kPa)	(0.02)	(0.02)	(0.02)	(0.02)	(0.02)	(0.02)	(0.02)	(0.02)	(0.02)	(0.02)
MAXIMUM CFM	3,700	4,625	5,550	6,475	7,401	8,326	9,251	11,101	12,951	14,801
(m ³ /s)	(1.746)	(2.183)	(2.620)	(3.056)	(3.493)	(3.930)	(4.366)	(5.240)	(6.113)	(6.986)
TEMP RISE - °F	20	20	20	20	20	20	20	20	20	20
(°C)	(11)	(11)	(11)	(11)	(11)	(11)	(11)	(11)	(11)	(11)
PRESSURE DROP - in. WC	2.03	1.92	1.81	1.86	1.90	1.93	1.96	2.00	2.02	2.05
(kPa)	(0.51)	(0.48)	(0.45)	(0.46)	(0.47)	(0.48)	(0.49)	(0.50)	(0.50)	(0.51)

NOTE:

Ratings are shown for unit installations at elevations between 0 and 2,000 ft. (610m). For unit installations in U.S.A. above 2,000 ft. (610m), the unit input must be field derated 4% for each 1,000 ft. (305m) above sea level; refer to local codes, or in absence of local codes, refer to the latest edition of the National Fuel Gas Code, ANSI Standard Z223.1 (NFPA 54). For installations in Canada, any references to deration at altitudes in excess of 2,000 ft. (610m) are to be ignored. At altitudes of 2,000 to 4,500 ft. (610 to 1372m), the unit must be orificed to 90% of the normal altitude rating, and be so marked in accordance with the ETL certification.

TEMPERATURE RISE AND PRESSURE DROP-GRAPH #1

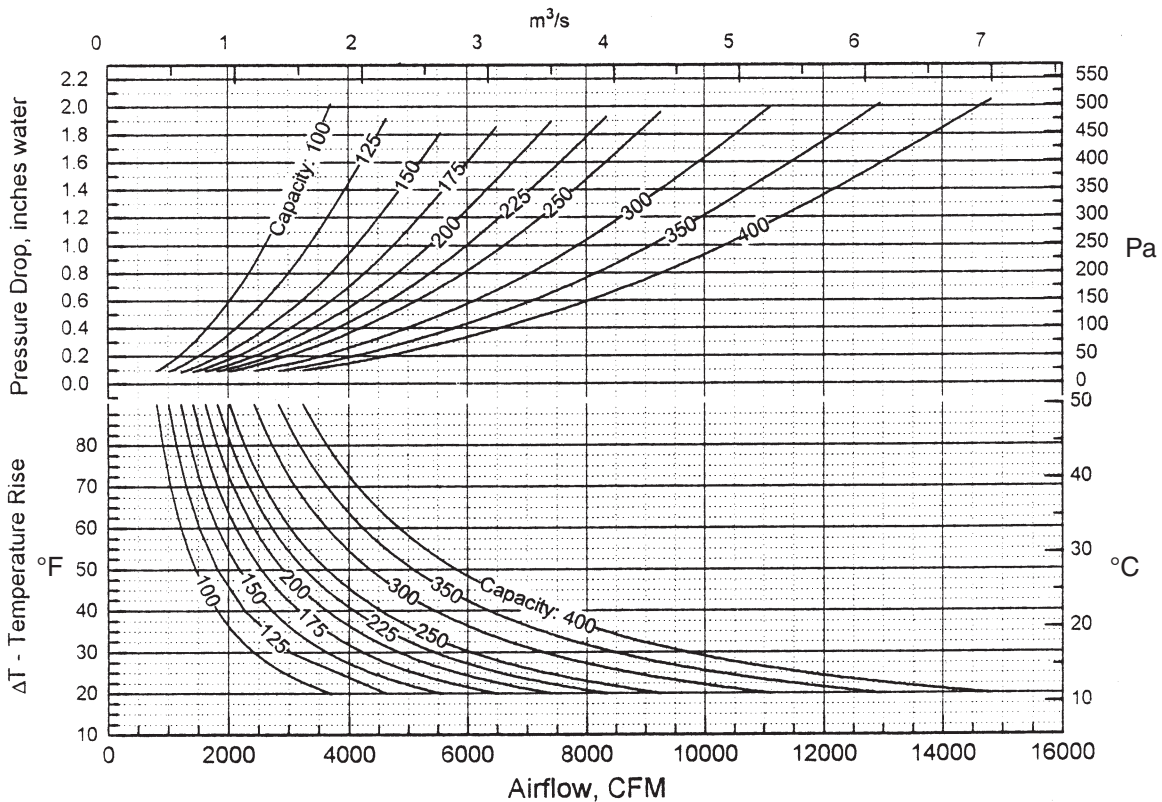

CLEARANCES

▲ WARNING Under no circumstances should combustible material be located within the clearances specified in Table 3. Failure to provide proper clearance could result in personal injury or equipment damage from fire.

Maintain adequate clearances around air openings into the combustion chamber:

Table 3 - Minimum Clearances

Sides	18" (457mm)
Top	6" (152mm)
Bottom	25" (635mm)
Flue	6" (152mm)

* When clearances required for accessibility are greater than the minimum required safety clearances, the accessibility clearances take precedence.

NOTICE: Increasing the clearance distances may be necessary if there is a possibility of distortion or discoloration of adjacent materials.

Atmospheres containing commercial solvents or chlorinated hydrocarbons will produce corrosive acids when coming in contact with the flames. This will greatly reduce the life of the duct furnace, and may void the warranty. Avoid such areas.

NOTICE: If the gas duct furnace is to be used in a building classified as having a hazardous atmosphere, the installation must comply with the standards set by the National Board of Fire Underwriters. Consult the authorities having jurisdiction before starting the job.

▲ WARNING The Separated Combustion Duct Furnace must be installed on the positive pressure side of the air circulation blower.

INSTALLATION

NOTICE: Furnace sizing should be based on heat loss calculations where the furnace output equals or exceeds heat loss.

▲ CAUTION Do not install duct furnaces in a corrosive or flammable atmosphere! Premature failure of, or severe damage to the unit will result!

▲ CAUTION Duct furnaces must not be installed in locations where air for combustion would contain chlorinated, halogenated, or acidic vapors. If located in such an environment, premature failure of the unit will occur!

ACCESSIBILITY: The Separated Combustion Duct Furnace is a bottom service access type. Allow a minimum of 25 inches (635mm) at the bottom of the unit to facilitate servicing the burners and pilot. Provision should be made to assure accessibility for recurrent maintenance purposes.

AIRCRAFT HANGARS: Separated Combustion Duct Furnaces must be installed in aircraft hangars as follows: Duct furnaces must be at least 10 feet (3.05m) above the upper surface of wings or engine enclosures of the highest aircraft to be stored in the hangar, and 8 feet (2.44m) above the floor in shops, offices, and other sections of the hangar where aircraft are not stored or housed. In Canada, installation is suitable in aircraft hangars when acceptable to the enforcing authorities.

PUBLIC GARAGES: In repair garages, duct furnaces must be installed in a detached building or room separated from repair areas as specified in the latest edition of NFPA 88B, Repair Garages.

In parking structures, duct furnaces must be installed so that the burner flames are located a minimum of 18 inches (457mm) above the floor or protected by a partition not less than 18 inches (457mm) high. Refer to the latest edition of NFPA 88A, Parking Structures.

In Canada, installation must be in accordance with the latest edition of CSA B149 "Installation Codes for Gas Burning Appliances and Equipment."

Separated Combustion Duct Furnaces should not be installed to maintain low temperatures and/or freeze protection of buildings. A minimum of 50°F (10°C) thermostat setting must be maintained. If duct furnaces are operated to maintain lower than 50°F (10°C), hot flue gases are cooled inside the heat exchanger to the point where water condenses onto the heat exchanger walls. The result is a mildly corrosive acid which prematurely corrodes the aluminized heat exchanger, and can actually drip water down from the duct furnace onto the floor surface. Additional duct furnaces should be installed if a minimum of 50°F (10°C) thermostat setting cannot be maintained.

DUCTWORK: Properly designed and installed ductwork, providing a uniformly distributed flow of air across the surfaces of the heat exchanger, is essential to satisfactory unit performance and life of the equipment.

All duct flanges/seams must be sealed to prevent air leaks. Sealant/tape must be suitable for temperatures of 250°F (121°C) minimum.

▲ WARNING Any attempt to straighten the 90° duct connection flanges on the duct furnace will affect the operation of the furnace and void the warranty.

INSTALLATION (Continued)

If uniform air distribution is not obtained, install additional baffles and/or turning vanes in the ductwork.

Access panels large enough to observe smoke and reflected light, and to detect the presence of leaks in the heating equipment, are required both upstream and downstream from the gas duct furnace. These panels must be sealed to prevent air leaks. If allowed by local regulations, install canvas connectors between the ductwork and fan discharge opening to eliminate the transmission of sound.

Figures 2 & 3 illustrate recommended ductwork designs for both the straight-through and elbowed air inlet arrangements.

AIR FLOW: The installation is to be adjusted to obtain an air throughput within the range specified on the appliance rating plate.

Figure 2 - Recommended Design for Field Installation of Ductwork for Straight-through Arrangement

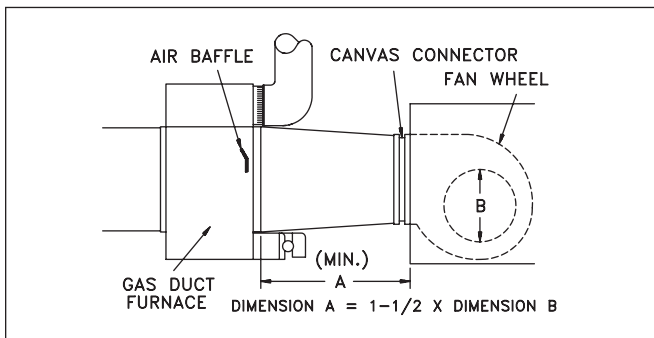
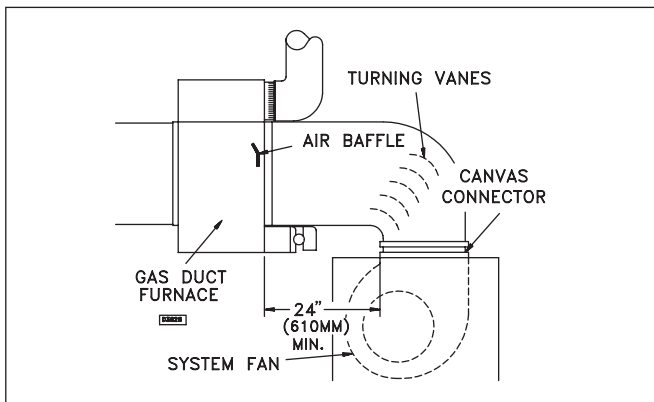

Figure 3 - Recommended Ductwork Design for Elbowed Arrangement



CONDENSATE: The duct furnace may be installed on the downstream side of a cooling coil, without need of a bypass duct. In some space conditions, condensate can form in the heat exchanger of the duct furnace when installed downstream from a cooling coil. Under these conditions, a field provided drain flange (also referred to as a waste nut) may be installed on the furnace bottom.

To install the drain flange, a hole should be drilled in the bottom of the burner section. The drain flange should then be bolted to the exterior of the unit, directly over the hole in the bottom of the drain pan. Any holes in the bottom of the pan not covered by the drain flange, should be sealed with RTV sealant. Condensate piping should terminate outside the building. Periodic cleaning of the condensate piping is required to ensure proper condensate flow.

BYPASS: When a gas duct furnace is installed to operate in conjunction with a summer air conditioning system, the cfm air delivery of the system blower should be adjusted to meet the design air volume requirements for cooling. If this cfm delivery is greater than that required for heating, resulting in a low air temperature rise, install a damper bypass around the gas duct furnace to bypass a portion of the air.

SUSPENSION: Refer to Figure 4 for typical suspension arrangements.

CAUTION The Separated Combustion Duct Furnace must be hung level from side to side, and from front to back, from four suspension points provided at the top of the unit. Failure to do so will result in poor performance and or premature failure of the unit. Refer to Figure 4 for typical suspension arrangements. **DO NOT** mount duct furnaces in series (one in front of another).

NOTICE: When mounting duct furnaces side by side, units must have opposite side gas connections (determined by Digit #6 - Furnace Type in the unit number). Minimum safety clearances must also be maintained; see Table 3. When service/accessibility clearances are greater than minimum safety clearances, service/accessibility clearances take precedence. See "Accessibility" section under "Installation".

WARNING Ensure that all hardware used in the suspension or for duct furnace is more than adequate for the job. Failure to do so may result in extensive property damage, severe personal injury or death!

INSTALLATION (Continued)

Figure 4 - Typical Four Point Duct Suspending Arrangement

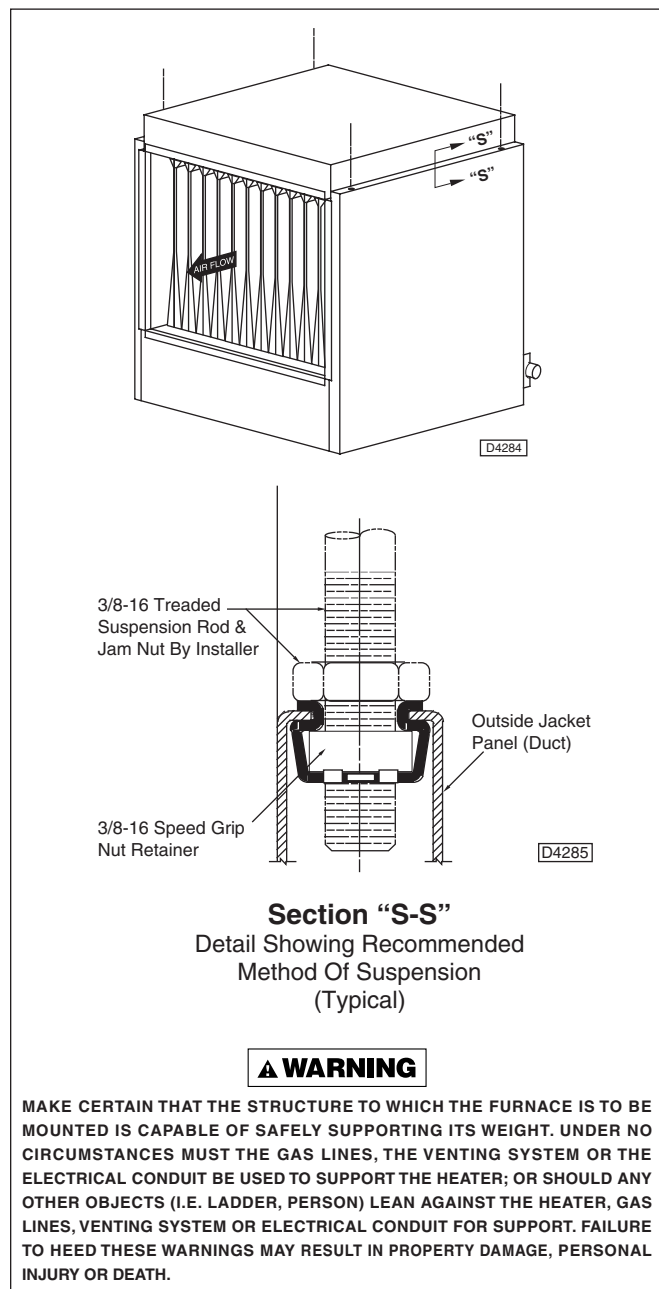

ELECTRICAL CONNECTIONS

⚠ WARNING

HAZARDOUS VOLTAGE! disconnect ALL ELECTRIC POWER INCLUDING REMOTE DISCONNECTS BEFORE SERVICING. Failure to disconnect power before servicing can cause severe personal injury or death.

Standard units are shipped for use on 115 volt, 60 hertz, single phase electric power. The motor name-plate and electrical rating of the transformer should be checked before energizing the duct furnace electrical system. All external wiring must conform to the latest edition of ANSI/NFPA No. 70, National Electrical Code, and applicable local codes; in Canada, to the Canadian Electrical Code, Part 1, CSA Standard C22.1

⚠ CAUTION Do not use any tools (i.e. screwdriver, pliers, etc.) across the terminals to check for power. Use a voltmeter.

⚠ CAUTION *USE COPPER CONDUCTORS ONLY!* UNIT TERMINALS ARE NOT DESIGNED TO ACCEPT OTHER TYPES OF CONDUCTORS. Failure to do so may cause damage to the equipment

It is recommended that the electrical power supply to each duct furnace be provided by a separate, fused, and permanently live electrical circuit. A disconnect switch of suitable electrical rating should be located as close to the gas valve as possible. Each duct furnace must be electrically grounded in accordance with the latest edition of the National Electrical Code, ANSI/NFPA No. 70, or CSA Standard C22.1 Sample wiring diagrams are shown in Figures 6, and 7.

Table 4 - Full Load Current In Amperes

Ampere Values Apply to All Unit Capacities	
Amps at 115 Volts	1.9
Amps at 208 Volts	1.1
Amps at 230 Volts	1.0
Amps at 460 Volts	0.5
Amps at 575 Volts	0.4

INSTALLATION (Continued)

THERMOSTAT WIRING AND LOCATION

NOTICE: The thermostat must be mounted on a vertical, vibration-free surface, free from air currents, and in accordance with the furnished instructions.

Mount the thermostat approximately 5 feet (1.5m) above the floor, in an area where it will be exposed to a free circulation of average temperature air. Always refer to the thermostat instructions, as well as our unit wiring diagram, and wire accordingly. Avoid mounting the thermostat in the following locations:

1. Cold Areas- Outside walls or areas where drafts may affect the operation of the control.
2. Hot Areas- Areas where the sun's rays, radiation, or warm air currents may affect the operation of the control.
3. Dead Areas- Areas where the air cannot circulate freely, such as behind doors or in corners.

NOTICE: Thermostat wires tagged "W" and "G" must be connected together except when using a general purpose "SPDT" 24VAC relay and standard thermostat with a subbase, or when using a Honeywell T834H or T834N thermostat. Also refer to Figure 5 for other wiring connections.

Figure 5 - C1267G

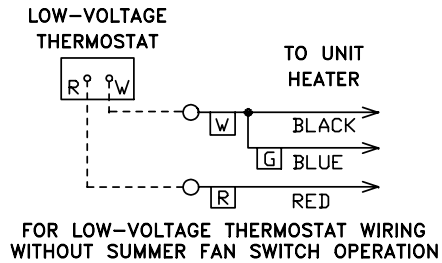

THERMOSTAT HEAT ANTICIPATOR ADJUSTMENTS

The initial heat anticipator setpoint should equal the thermostat's current amperage draw when the unit is firing. This setpoint should be measured for the best results. Use the recommended ranges for a guide. If further information is needed, consult your thermostat manufacturer's instructions.

Recommended heat anticipator setting ranges:	
25 feet (7.6m) T'stat wiring	50 feet T'stat wiring
0.85 to 0.90 A	0.90 to 1.1 A Max. setting on t'stat

Figure 6 - Standard Wiring Diagram for Unit with Honeywell Ignition System.

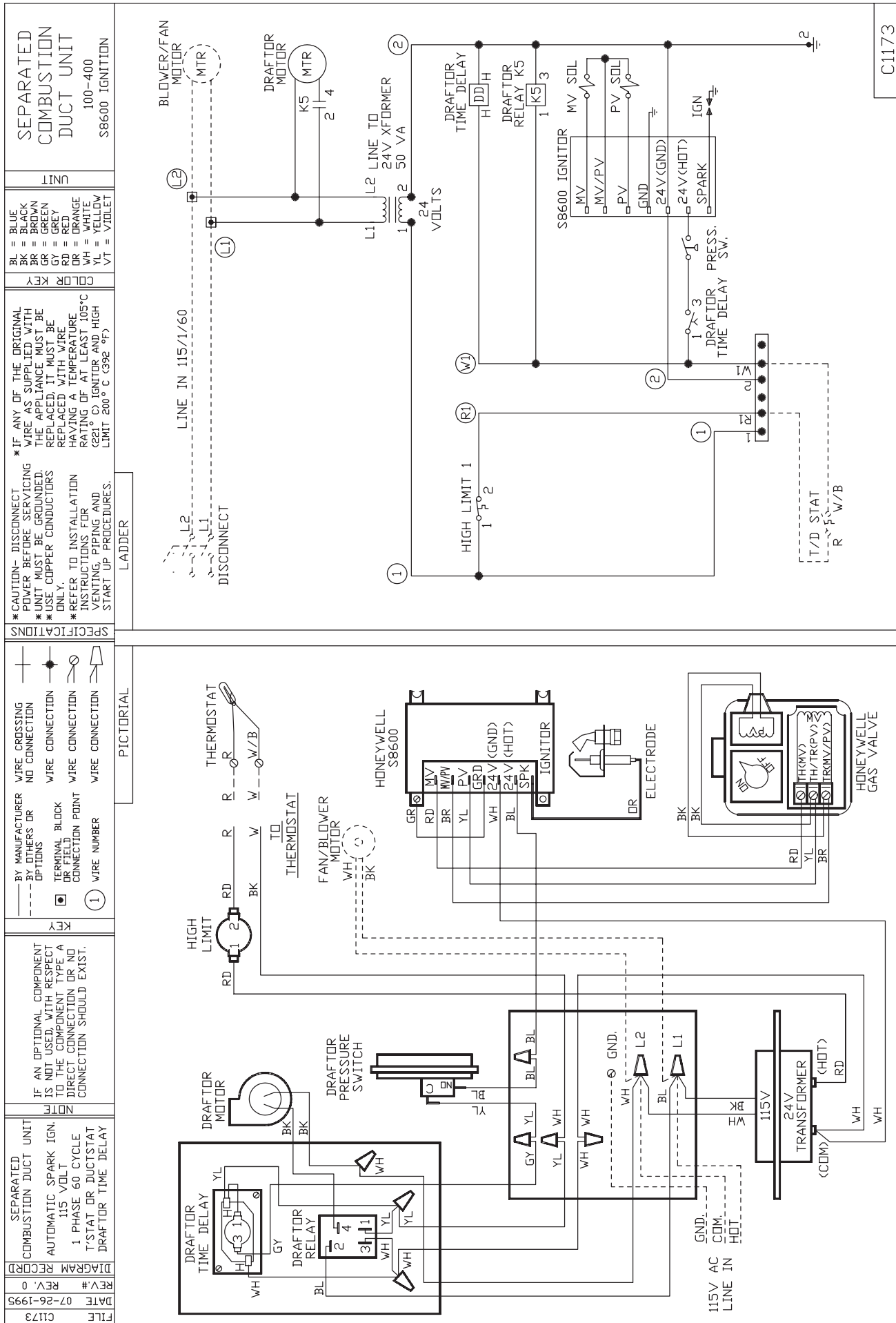
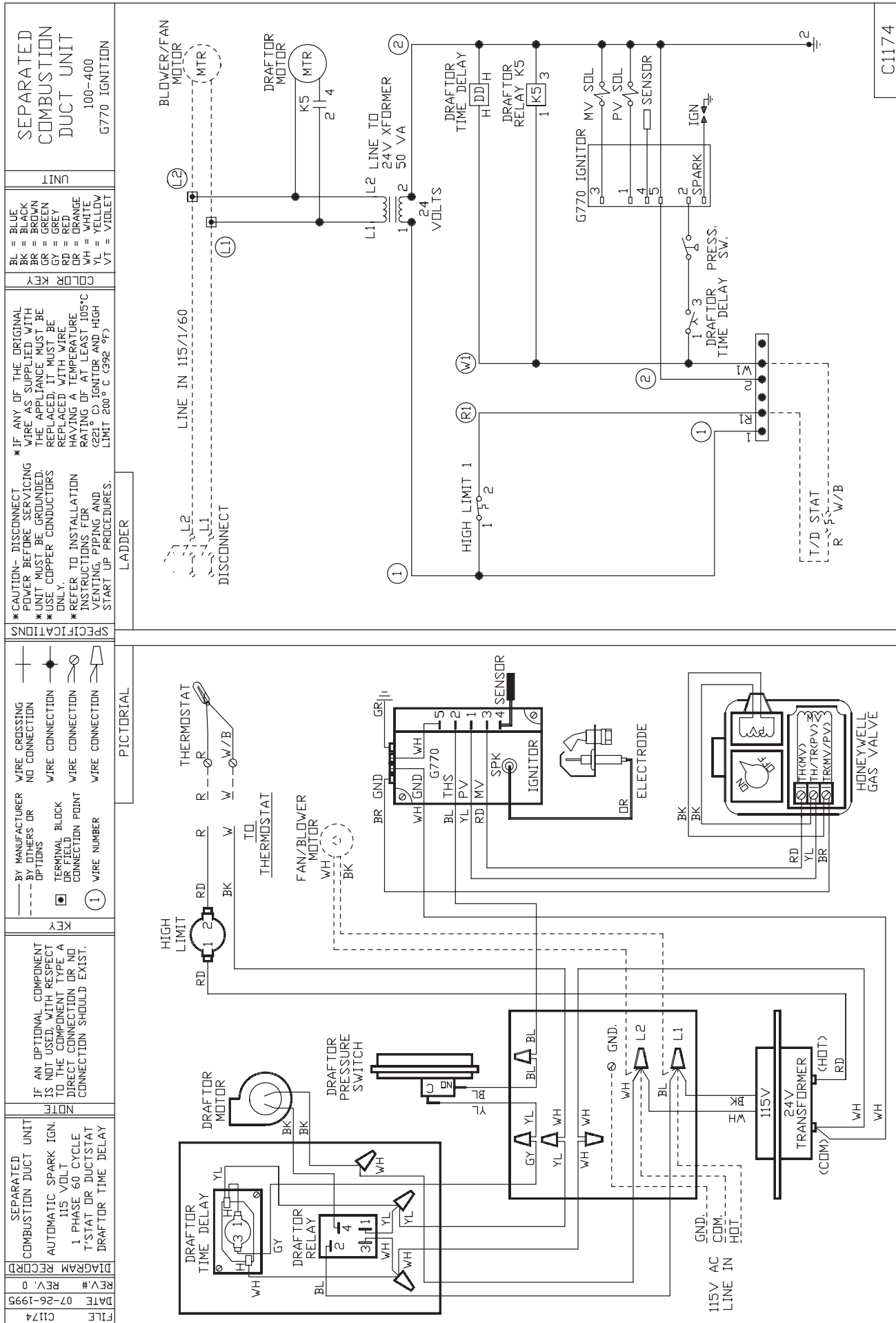

Figure 7 - Standard Wiring Diagram for Unit with Johnson Ignition System



INSTALLATION (Continued)

FAN TIME DELAY CONTROL (OPTIONAL)

Leads from the fan time delay control are factory wired to the junction box (when ordered as an optional component). The fan time delay control is a time delay relay (approximately 45 seconds ON, 65 seconds OFF). The fan time delay control is rated at 17 amps.

NOTICE: The start-up fan delay should not exceed 90 seconds from a cold start.

IMPORTANT: For all wiring connections, refer to the wiring diagram shipped with your unit (either affixed to the side jacket or enclosed in the installation instructions envelope). Should any original wire supplied with the heater have to be replaced, it must be replaced with wiring material having a temperature rating of at least 105°C.

Should any high limit wires have to be replaced, they must be replaced with wiring material having a temperature rating of 200°C minimum.

POWER VENT POSITION

Units are shipped from the factory set up for horizontal venting. To convert the power venter for vertical or opposite side venting, remove the shipping support bracket, and follow this procedure:

1. Hold power venter motor in position.
2. Remove the three Phillips-head screws from the motor adaptor plate.
3. Remove the three screws which connect the power venter stack to the power venter housing.
4. Rotate the power venter housing to the desired position.
5. Replace screws accordingly.

NOTICE: The motor, pressure switch, and junction box bracket **MUST** remain located as shipped from the factory. Rotate only the blower housing! If the power venter housing is to be moved to the right horizontal position, the junction box must be rotated 90 degrees CCW to clear the connection. To do this, remove all wires, conduit and conduit connector from the junction box, noting location of wires. Move box, using holes provided. Move 7/8 inch plug from bottom of box to side. Reconnect all wires according to the unit's wiring diagram.

COMBUSTION AIR INLET SYSTEM PIPING

▲ WARNING Never operate duct furnaces without combustion air and flue gas piping in place, or severe personal injury or death may occur!

▲ WARNING CARBON MONOXIDE!

Your venting system must not be blocked by any snow, snow drifts, or any foreign matter. Inspect your venting system to ensure adequate ventilation exists at all times! Failure to heed these warnings could result in Carbon Monoxide Poisoning (symptoms include grogginess, lethargy, inappropriate tiredness, or flu-like symptoms).

1. The combustion air system installation must be in accordance with the latest edition of National Fuel Gas Code-NFPA 54, ANSI Z223.1 National Fuel Gas Code. In Canada, installation must be in accordance with CSA-B149.1 "Installation Code for Natural Gas Burning Appliances and Equipment" or CSA-B149.2 "Installation Code for Propane Burning Appliances and Equipment".
2. A Breidert Type L or Fields inlet cap furnished by the customer, must be installed at the termination point of the combustion air system, Figures 8 & 9.

NOTICE: The top of the cap is to be no less than 12 inches from the top of the exhaust vent cap. See Figures 8 & 9.

3. Each duct furnace **MUST** have its own combustion air system. It **MUST NOT** be connected to other air intake systems.
4. Use single wall pipe constructed of 26 gauge galvanized steel, or material of equivalent durability and corrosion resistance for the combustion air inlet system. For installations in Canada, use pipe constructed from .025 inch thick aluminum or 0.018 inch thick steel.

▲ WARNING Never use a pipe of a diameter other than that specified in Table 1, ("D" dia. flue opening)! Never use PVC/ABS or other non-metallic pipe for venting! To do so may result in serious damage to the unit, or severe personal injury or death!

INSTALLATION (Continued)

5. Long runs of single wall combustion air piping passing through an unheated space may require insulating if condensation becomes noticeable.
6. The combustion air system must be installed to prevent collection of condensate. Pitch horizontal pipes downward 1/4 inch per foot (21mm/m) toward the inlet cap to facilitate drainage. Vertical combustion air pipes should be arranged as depicted in Figure 9.
7. The equivalent length of the combustion air system must not be less than 5 feet (1.5m) and must not exceed 50 feet (15.2m). Equivalent length is the total length of straight sections PLUS 10 feet (3.05m) for each 90° elbow and 5 feet (1.5m) for each 45° elbow.

NOTICE: For optimum performance, keep the combustion air system as straight as possible.

8. Each slip joint must be secured with at least three corrosion resistant screws. Two full turns of 3M #425 Aluminum Foil Tape or its equivalent must be used to seal each joint. General Electric RTV-108, Dow-Corning RTV-732, or an equivalent, may be used instead of the tape.
9. For horizontal combustion air systems longer than 5 feet (1.5m), the system must be supported from overhead building structures at 3 feet (1m) intervals.

EXHAUST VENTING - CATEGORY III

▲ WARNING Never operate duct furnaces without combustion air and flue gas piping in place, or severe personal injury or death may occur!

1. Vent system installation must be in accordance with the latest edition of National Fuel Gas Code-NFPA 54, ANSI Z223.1 National Fuel Gas Code. In Canada, installation must be in accordance with CSA-B149.1 "Installation Code for Natural Gas Burning Appliances and Equipment" or CSA-B149.2 "Installation Code for Propane Burning Appliances and Equipment".
2. A Breidert Type L or Fields vent cap furnished by the customer, must be installed at the termination point of the vent system, Figures 8 & 9.
3. Each unit MUST have its own vent system. It MUST NOT be connected to other vent systems or to a chimney.
4. Use UL 1738 listed single wall pipe for the vent system. For installation in Canada, use corrosion resistant and gas-tight, listed vent pipe conforming with local building codes, or in the absence of local building codes, with current CSA-B149.1, Installation Codes for Natural Gas Burning Appliances and Equipment or CSA-B149.2, Installation Codes for Propane Gas Burning Appliances and Equipment.

▲ WARNING Never use a pipe of a diameter other than that specified in Table 1, ("D" dia. flue opening)! Never use PVC/ABS or other non-metallic pipe for venting! To do so may result in serious damage to the unit or severe personal injury or death!

5. Any run of single wall vent pipe passing through an unheated space must be insulated with an insulation suitable to 550°F.
6. The combustion and exhaust vent air systems must be installed to prevent collection of condensate. Pitch horizontal pipes downward 1/4 inch per foot (21mm/m) toward the terminal caps to facilitate drainage (see Figure 8A). Vertical vent pipes should be arranged as depicted in Figure 8.
7. The equivalent length of the vent system must not be less than 5 feet (1.5m) and must not exceed 50 feet (15.2m). Equivalent length is the total length of straight sections PLUS 10 feet (3.05m) for each 90° elbow and 5 feet (1.5m) for each 45° elbow.
8. Each slip joint must be secured with at least three corrosion resistant screws. Two full turns of 3M #425 Aluminum Foil Tape or its equivalent must be used to seal each joint. General Electric RTV-108, Dow-Corning RTV-732, or an equivalent, may be used instead of the tape.
9. For horizontal vent systems longer than 5 feet (1.5m), the system must be supported from overhead building structures at 3 feet (1m) intervals.
10. The exhaust vent system must remain at a minimum of 6 inches (152mm) from all combustible materials. Any part of the vent system that passes through a combustible material must be properly insulated.

NOTICE: Increasing the clearance distance may be necessary if there is a possibility of distortion or discoloration of adjacent materials.

For a VERTICAL vent pipe section that passes through a floor or roof, an opening 4 inches (102mm) greater in diameter is required. The opening must be insulated and flashed in accordance with applicable installation codes.

A HORIZONTAL section of an exhaust vent system that passes through a combustible wall must be constructed and insulated as shown in Figure 9A.

11. The top of a VERTICALLY VENTED exhaust system must extend at least 3 feet (1m) above the roof surface that it passes through. The point of termination for a HORIZONTALLY VENTED exhaust system must be at least 12 inches (305mm) from the exterior wall that it passes through. See Vent System Termination Clearance Requirements in Table 5. See Vent/Intake Installations in Figures 8 & 8A.

INSTALLATION (Continued)

Vent Systems Termination Clearance Requirements		
Structure/Object	Minimum Clearance for Termination Locations	
	USA	CANADA
Door, window, or gravity vent inlet; combustion air inlet for other appliances	9 inches for 10,000 to 50,000 BTU/Hr input; 12 inches for input exceeding 50,000 BTU/Hr.	9 inches (230mm) for 10,000 to 50,000 BTU/Hr input; 12 inches (305mm) for input exceeding 50,000 BTU/Hr.
Forced air inlet within 10 feet	3 feet above	6 feet (1.8m)
Adjoining Building or parapet	10 feet	10 feet (3.04m)
Adjacent public walkways	7 feet above grade	7 feet (2.1m) above grade
Electric, gas meters & regulators	4 feet horizontal	3 feet (0.9m) horizontally from meter/regulator assembly. 6 feet (1.8m), any direction, from a gas service regulator vent outlet
Above grade level*	1 feet	1 feet (0.3m)

*Minimum above maximum snow depth, or per local code, whichever is greater.

Figure 8. Vertical Intake/Vent Installation

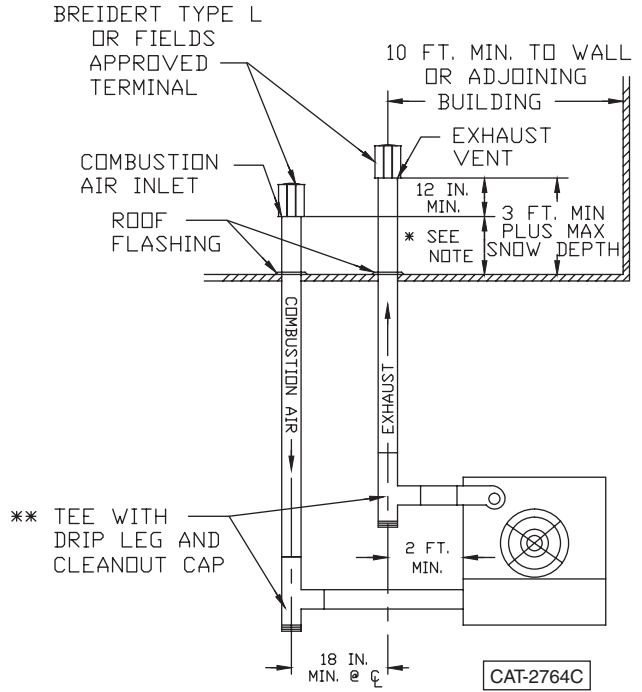

* 2 FT. Min plus max snow depth for area.

** If excessive condensation develops, a drip leg with a condensate drain may be required. Insulating the pipes may eliminate the problem.

Figure 8A. Horizontal Intake/Vent Locations

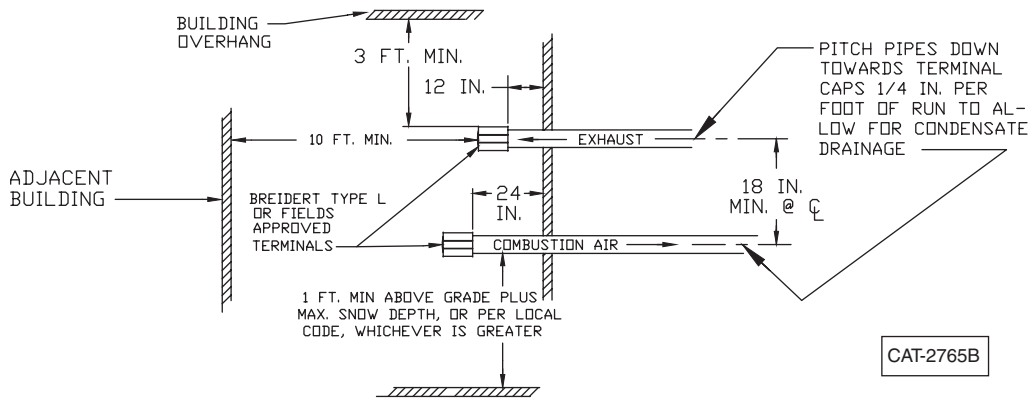

Figure 9. Vertical Vent Installation

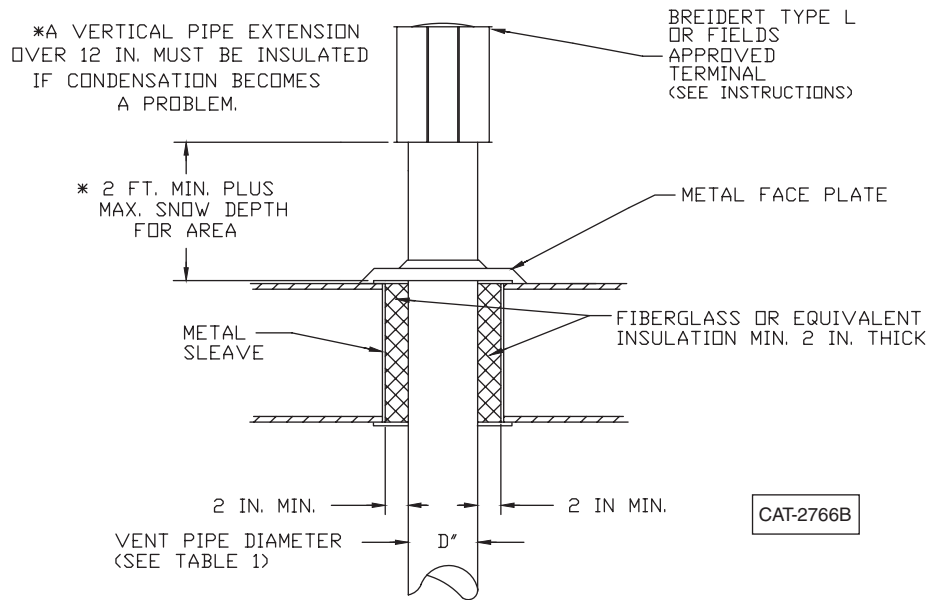
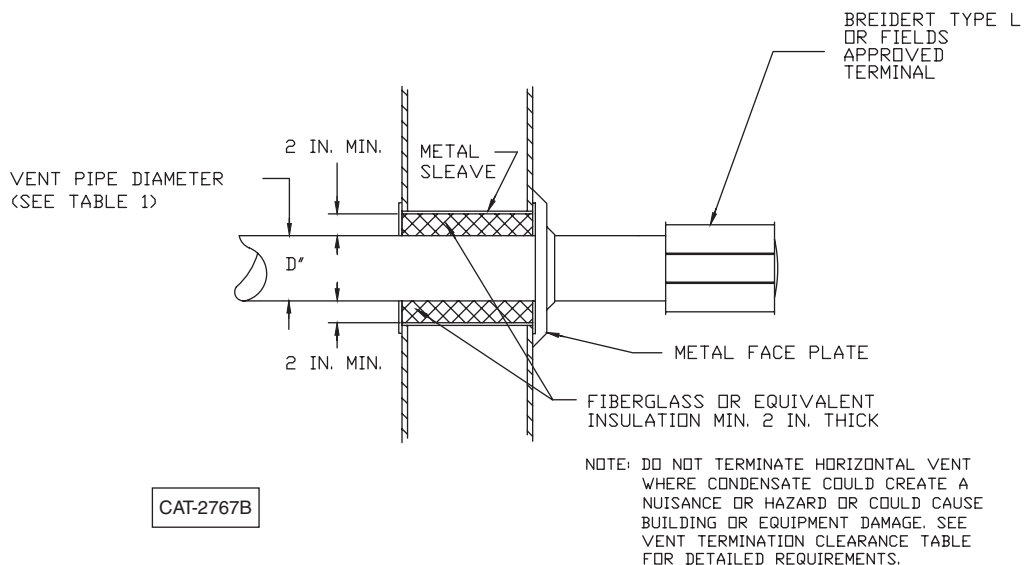

Figure 9A. Horizontal Vent Installation



GAS PIPING

▲ WARNING To avoid damage or possible personal injury, do not connect gas piping to this unit until a supply line pressure/leak test has been completed. Connecting the unit before completing the pressure/leak test may damage the gas valve and result in fire hazard.

▲ WARNING Do not rely on a shut-off valve to isolate the unit while conducting gas pressure/leak tests. These valves may not be completely shut off, exposing the gas valve to excessive pressure and damages.

PIPE SIZING

To provide adequate gas pressure to the gas duct furnace, size the gas piping as follows:

1. Find cu. ft./hr. by using the following formula:

$$\text{Cu. ft./hr.} = \frac{\text{Input}}{\text{BTU/Cu. ft.}}$$

2. Refer to Table 6. Match "Length of Pipe in Feet" with appropriate "Gas Input - Cu. Ft./Hr." figure. This figure can then be matched to the pipe size at the top of the column.

Example:

It is determined that a 67 foot (20.4m) run of gas pipe is required to connect a 200 MBTU gas duct furnace to a 1,000 BTU/cu. ft. (0.29kW) natural gas supply.

$$\frac{200,000 \text{ BTU/Hr}}{1,000 \text{ BTU/Cu. ft.}} = 200 \text{ Cu. ft./hr.}$$

Using Table 6, a 1 inch pipe is needed.

NOTICE: See General Safety Information section for English/Metric unit conversion factors.

NOTICE: If more than one duct furnace is to be served by the same piping arrangement, the total cu. feet/hr. input and length of pipe must be considered.

NOTICE: If the duct furnace is to be fired with LP gas, consult your local LP gas dealer for pipe size information.

NOTICE: Heater installation for use with propane (bottled) gas must be made by a qualified LP gas dealer or installer. He will insure that proper joint compounds are used for making pipe connections; that air is purged from lines; that a thorough test is made for leaks before operating the heater; and that it is properly connected to the propane gas supply system.

Before any connection is made to the existing line supplying other gas appliances, contact the local gas company to make sure that the existing line is of adequate size to handle the combined load.

Table 6 - Gas Pipe Size

Maximum Capacity of Pipe in Cubic Feet of Gas per Hour (Cubic Meters per Hour) for Gas Pressures of 0.5 psig (3.5 kPa) or Less, and a Pressure Drop of 0.5 Inch Water Column (124.4 Pa)
(Based on a 0.60 Specific Gravity Gas)

Nominal Iron	Internal Dia.	Length of Pipe, Feet (meters)													
		10 (3.0)	20 (6.1)	30 (9.1)	40 (12.2)	50 (15.2)	60 (18.3)	70 (21.3)	80 (24.4)	90 (27.4)	100 (30.5)	125 (38.1)	150 (45.7)	175 (53.3)	200 (61.0)
1/2	0.622	175 (4.96)	120 (3.40)	97 (2.75)	82 (2.32)	73 (2.07)	66 (1.87)	61 (1.73)	57 (1.61)	53 (1.50)	50 (1.42)	44 (1.25)	40 (1.13)	37 (1.05)	35 (0.99)
3/4	0.824	360 (10.2)	250 (7.08)	200 (5.66)	170 (4.81)	151 (4.28)	138 (3.91)	125 (3.54)	118 (3.34)	110 (3.11)	103 (2.92)	93 (2.63)	84 (2.38)	77 (2.18)	72 (2.04)
1	1.049	680 (19.3)	465 (13.2)	375 (10.6)	320 (9.06)	285 (8.07)	260 (7.36)	240 (6.80)	220 (6.23)	205 (5.80)	195 (5.52)	175 (4.96)	160 (4.53)	145 (4.11)	135 (3.82)
1 1/4	1.380	1400 (39.6)	950 (26.9)	770 (21.8)	660 (18.7)	580 (16.4)	530 (15.0)	490 (13.9)	460 (13.0)	430 (12.2)	400 (11.3)	360 (10.2)	325 (9.20)	300 (8.50)	280 (7.93)
1 1/2	1.610	2100 (59.5)	1460 (41.3)	1180 (33.4)	990 (28.0)	900 (25.5)	810 (22.9)	750 (21.2)	690 (19.5)	650 (18.4)	620 (17.6)	550 (15.6)	500 (14.2)	460 (13.0)	430 (12.2)
2	2.067	3950 (112)	2750 (77.9)	2200 (62.3)	1900 (53.8)	1680 (47.6)	1520 (43.0)	1400 (39.6)	1300 (36.8)	1220 (34.5)	1150 (32.6)	1020 (28.9)	950 (26.9)	850 (24.1)	800 (22.7)
2 1/2	2.469	6300 (178)	4350 (123)	3520 (99.7)	3000 (85.0)	2650 (75.0)	2400 (68.0)	2250 (63.7)	2050 (58.0)	1950 (55.2)	1850 (52.4)	1650 (46.7)	1500 (42.5)	1370 (38.8)	1280 (36.2)
3	3.068	11000 (311)	7700 (218)	6250 (177)	5300 (150)	4750 (135)	4300 (122)	3900 (110)	3700 (105)	3450 (97.7)	3250 (92.0)	2950 (83.5)	2650 (75.0)	2450 (69.4)	2280 (64.6)
4	4.026	23000 (651)	15800 (447)	12800 (362)	10900 (309)	9700 (275)	8800 (249)	8100 (229)	7500 (212)	7200 (204)	6700 (190)	6000 (170)	5500 (156)	5000 (142)	4600 (130)

1. Determine the required Cu. feet / Hr. by dividing the rated heater input by 1000. For SI / Metric measurements: Convert unit Btu. / Hr. to kilowatts. Multiply the units input (kW) by 0.0965 to determine Cubic Meters / Hour. 2. FOR NATURAL GAS: Select the pipe size directly from the table. 3. FOR PROPANE GAS: Multiply the Cu. feet / Hr. (Cubic Meters per Hour) value by 0.633; then use the table. 4. Refer to the metric conversion factors listed in General Safety section for more SI unit measurements/conversions.

PIPE INSTALLATION

1. Install the gas piping in accordance with applicable local codes.
2. Check gas supply pressure. Each duct furnace must be connected to a manifold pressure and a gas supply capable of supplying its full rated capacity as specified in Table 7. A field LP tank regulator must be used to limit the supply pressure to a maximum of 14 inches WC (3.5 kPa). All piping should be sized in accordance with the latest edition of ANSI Standard Z223.1 (NFPA 54), National Fuel Gas Code; in Canada, according to CSA B149. See Tables 1, 6 & 7 (of this manual) for correct gas piping size. If gas pressure is excessive on natural gas applications, install a pressure regulating valve in the line upstream from the main shutoff valve.
3. Adequately support the piping to prevent strain on the gas manifold and controls.
4. To prevent the mixing of moisture with gas, run the take-off piping from the top, or side, of the main.
5. Duct furnaces are shipped with a combination valve which includes:
 - a. Manual "A" valve
 - b. Manual "B" valve
 - c. Solenoid valve
 - d. Pilot safety
 - e. Pressure regulator

Pipe directly into the combination valve (see Figure 10).

6. A 1/8 inch N.P.T. plugged tapping, accessible for test gauge connection, must be installed immediately upstream of the gas supply connection to the appliance.
7. Provide a drip leg in the gas piping near the gas duct furnace. A ground joint union and a manual gas shutoff valve should be installed ahead of the unit heater controls to permit servicing. The manual shutoff valve must be located external to the jacket (See Figure 10).
8. Make certain that all connections have been adequately doped and tightened.

▲ CAUTION Do not over tighten the inlet gas piping into the valve. This may cause stresses that will crack the valve!

NOTICE: Use pipe joint sealant resistant to the action of liquefied petroleum gases regardless of gas conducted.

▲ WARNING Check all pipe joints for leakage using a soap solution or other approved method. Never use an open flame or severe personal injury or death may occur!

Figure 10- Pipe Installation, Standard Controls

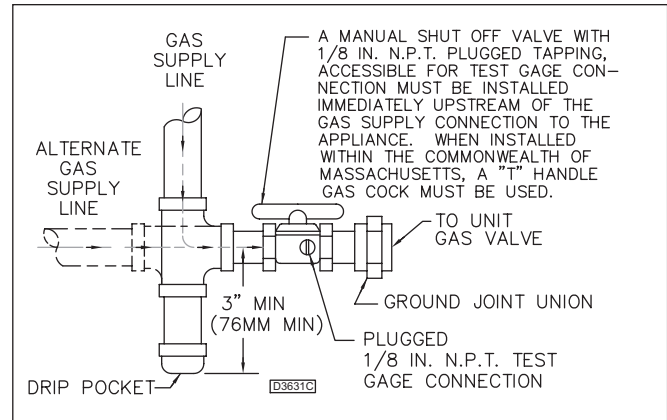

▲ DANGER Never use an open flame to detect gas leaks. Explosive conditions may exist which will result in personal injury or death.

The appliance and its individual shutoff valve must be disconnected from the gas supply piping system during any pressure testing of that system in excess of 1/2 psig (3.5 kPa).

The appliance must be isolated from the gas supply piping system by closing its individual manual shutoff valve during any pressure testing of the gas supply piping system at test pressures equal to or less than 1/2 psig (3.5 kPa).

PIPE INSTALLATION (Continued)

Table 7 - Gas Supply Pressure Requirements

Heating Value	Natural Gas	Propane Gas
	1075 Btu/Ft ³ (40.1 MJ/m ³)	2500 Btu/Ft ³ (93.1 MJ/m ³)
Manifold Pressure		
Single Stage Application	3.5 in. WC (0.87 kPa)	10.0 in. WC (2.49 kPa)
Two Stage Application - High Fire	3.5 in. WC (0.87 kPa)	10.0 in. WC (2.49 kPa)
Two Stage Application - Low Fire	1.1 in. WC (0.27 kPa)	3.8 in. WC (0.95 kPa)
Modulating Application - High Fire	3.5 in. WC (0.87 kPa)	10.0 in. WC (2.49 kPa)
Modulating Application - Low Fire	0.9 in. WC (0.22 kPa)	3.5 in. WC (0.87 kPa)
Minimum Supply Pressure		
Single Stage Application	5.0 in. WC (1.24 kPa)	11.0 in. WC (2.74 kPa)
Two Stage Application	6.5 in. WC (1.62 kPa)	11.5 in. WC (2.86 kPa)
Modulating Application	6.5 in. WC (1.62 kPa)	11.5 in. WC (2.86 kPa)
Maximum Supply Pressure	14.0 in. WC (3.49 kPa)	14.0 in. WC (3.49 kPa)

GAS INPUT RATE

▲ CAUTION Never overfire the duct furnace, as this may cause unsatisfactory operation, or shorten the life of the heater.

Check the gas input rate as follows (Refer to General Safety Information section for metric conversions).

1. Turn off all gas appliances that use gas through the same meter as the unit heater.
2. Turn the gas on to the unit heater.
3. Clock the time in seconds required to burn 1 cubic ft. of gas by checking the gas meter.
4. Insert the time required to burn one cubic foot of gas into the following formula and compute the input rate

$$\frac{3600 \text{ (Sec. per Hr.)} \times \text{BTU/Cu.}/\text{Ft.}}{\text{Time (Sec.)}} = \text{Input Rate}$$

For example, assume the BTU content of one cubic foot of gas is 1000, and that it takes 18 seconds to burn one cubic foot of gas.

$$\frac{3600 \times 1000}{18} = 200,000$$

NOTICE: If the computation exceeds, or is less than 95% of the gas BTU/hr. input rating (see Table 2), adjust the gas pressure.

Adjust the gas pressure as follows:

1. **NATURAL GAS:** Best results are obtained when the duct furnace is operating at its full rated input with the manifold pressure of 3.5 inch WC (0.9 kPa). Adjustment of the pressure regulator is not normally necessary since it is preset at the factory. However, field adjustment may be made as follows:
 - a. Attach manometer at the pressure tap plug below the control outlet.
 - b. Remove the regulator adjustment screw cap, located on the combination gas valve.
 - c. With a small screwdriver, rotate the adjustment screw clockwise to increase pressure.
 - d. Replace regulator adjustment screw cap.
2. **PROPANE GAS:** An exact manifold pressure of 10.0 inch WC (2.5 kPa) must be maintained for proper operation of the duct furnace. If the unit is equipped with a pressure regulator on the combination gas valve, follow steps “a” through “d” above. If the unit is not so equipped, the propane gas supply system pressure must be regulated to attain this manifold operating pressure.

Table 8 - Main Burner Orifice Schedule*

*	TYPE OF GAS	NATURAL	PROPANE	NO. OF BURNER ORIFICES
		HEATING VALUE	HEATING VALUE	
INPUT IN 1000 BTU		1075 BTU/Ft ³ (40.1 MJ/m ³)	2500 BTU/Ft ³ (93.1 MJ/m ³)	
	MANIFOLD PRESSURE	3.5 Inch WC (0.9 kPa)	10.5 Inch WC (2.6 kPa)	
100	FT ³ /HR ORIFICE DRILL	96 42	40 54	4
125	FT ³ /HR ORIFICE DRILL	120 42	50 54	5
150	FT ³ /HR ORIFICE DRILL	140 42	60 54	6
175	FT ³ /HR ORIFICE DRILL	163 42	70 54	7
200	FT ³ /HR ORIFICE DRILL	186 42	80 54	8
225	FT ³ /HR ORIFICE DRILL	210 42	90 54	9
250	FT ³ /HR ORIFICE DRILL	233 42	100 54	10
300	FT ³ /HR ORIFICE DRILL	280 42	120 54	12
350	FT ³ /HR ORIFICE DRILL	326 42	140 54	14
400	FT ³ /HR ORIFICE DRILL	372 42	160 54	16

* This schedule is for units operating at normal altitudes of 2000 feet (610m) or less. Special orifices are required for installations above 2000 feet (610m).

When installed in Canada, any references to deration at altitudes in excess of 2000 feet (610m) are to be ignored. At altitudes of 2000 to 4500 feet (610 to 1372m), the unit heaters must be orificed to 90% of the normal altitude rating, and be so marked in accordance with the ETL certification.

PILOT ADJUSTMENT

1. Remove the PILOT ADJUSTMENT CAP.
2. Adjust the pilot screw to provide a properly sized flame.
3. A proper flame is a soft, steady flame that envelops 3/8 to 1/2 inches (9.5 to 12.7mm) of the flame sensor.
4. Replace the pilot adjustment cap.

MANIFOLD PRESSURE ADJUSTMENT

If the manifold pressure requires adjustment, remove the cap from the pressure regulator and turn the adjustment screw clockwise to increase the pressure, and counterclockwise to decrease the pressure. The adjusted manifold pressure should not vary more than 10% from the pressures specified in Table 8.

Figure 11 - Burner Components – Intermittent Pilot Ignition

BURNER DRAWER COMMON PARTS:

- 1. MAIN BURNERS
- 2. BURNER MANIFOLD
- 3. AIR SHUTTERS
- 4. BURNER SPRINGS
- 5. MAIN BURNER ORIFICE
- 6. TRANSFORMER
- 7. PILOT TUBING

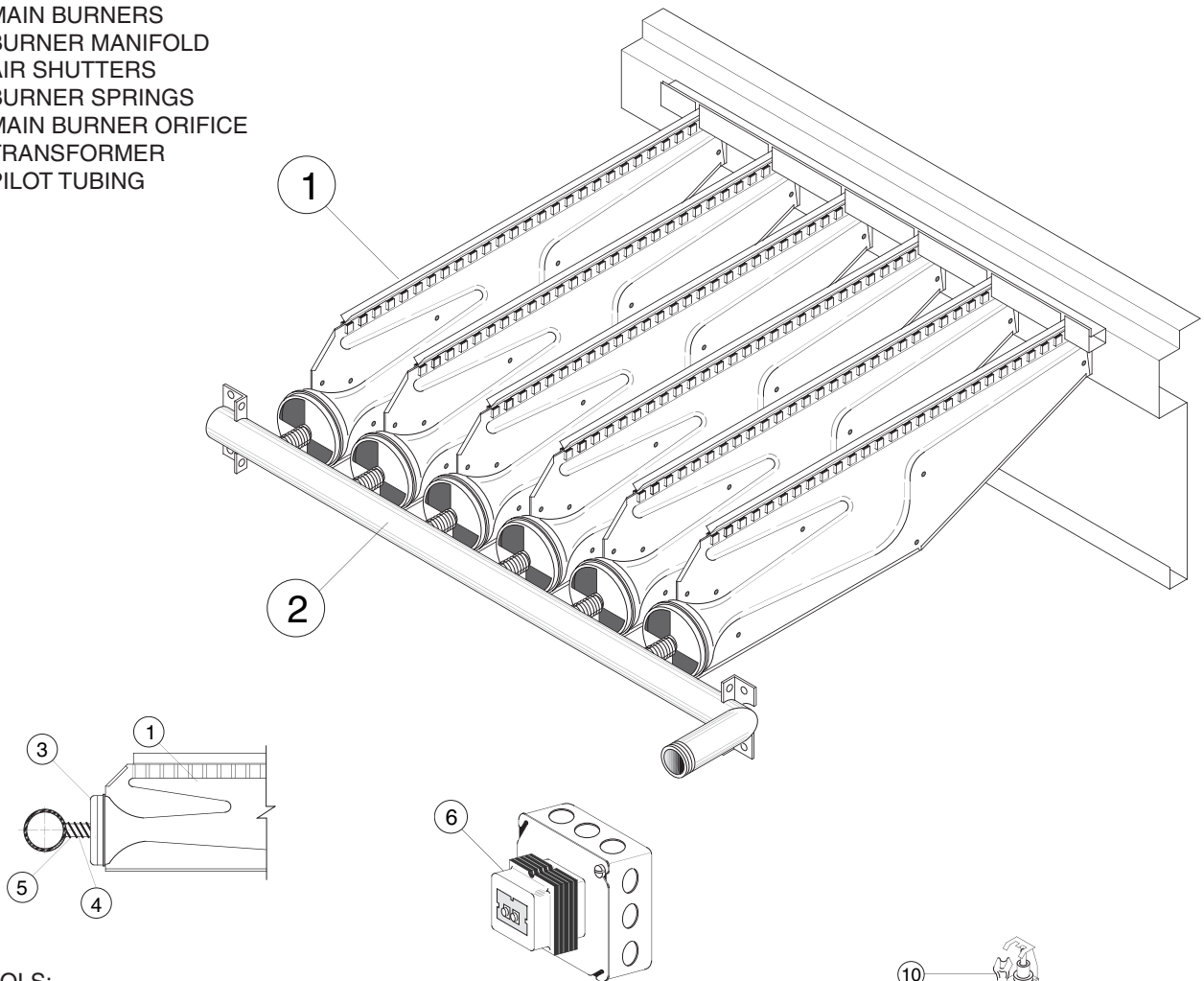

CONTROLS:

- 8A. MAIN GAS VALVE (HONEYWELL)
- 8B. MAIN GAS VALVE (WHITE RODGERS)
- 9. HONEYWELL IGNITOR
- 10. PILOT BURNER
- 11. PILOT ORIFICE
- 12. ELECTRODE/SENSOR LEAD
- 13. HIGH LIMIT
(LOCATED ON THE REAR HEADER PLATE OF THE HEAT EXCHANGER - AIR INLET SIDE).

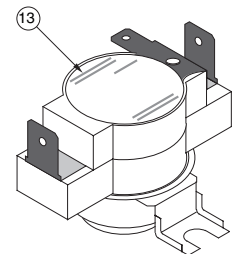
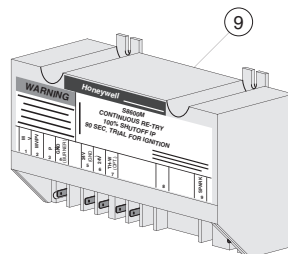
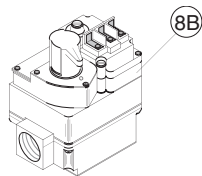
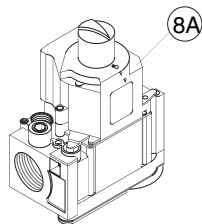
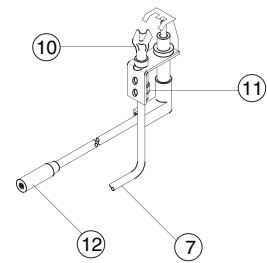

OPERATION

▲ CAUTION Never operate the unit beyond the specified limits or severe damage to, and/or premature failure of, the unit will result!

EXPLANATION OF CONTROLS

1. Each Separated Combustion Duct Furnace comes equipped with a power vent system that consists of a power ventor motor and blower, pressure switch, and sealed flue collector. (See Figure 15)

▲ CAUTION The addition of external draft hoods or power ventors is not permitted. Addition of such devices may cause serious unit malfunction or failure.

2. The power ventor is energized by the room thermostat when a demand for heat is sensed. The pressure switch measures the differential pressure between the air inlet and the exhaust vent systems. If the differential is correct, the indirect spark ignition system is energized.

▲ WARNING Under no circumstances is the unit to be fired if the power ventor is not operable, or severe personal injury or death may occur!

3. The indirect spark ignition system consists of an ignition module, a dual combination gas valve, and a spark-ignited pilot burner. When the pressure switch is closed, the pilot valve opens as a spark is generated to light the pilot. When the flame is sensed by the flame sensing circuit, the spark ceases, and the main gas valve opens to supply gas to the main burners. Once the thermostat is satisfied, the vent system and gas valve are simultaneously de-energized, stopping all gas flow to the unit.
4. The high limit switch interrupts the flow of electrical current to the main gas valve if the duct furnace becomes overheated.
5. The optional fan switch delays the operation of the fan for approximately 45 seconds once the thermostat is closed, and continues fan operation for approximately 65 seconds after the thermostat opens. The start-up fan delay must not exceed 90 seconds from a cold start.
6. The wall thermostat, supplied optionally, is a temperature sensitive switch that operates the vent and ignition systems to control the temperature of the space being heated.

NOTICE: The thermostat must be mounted on a vertical, vibration-free surface, free from air currents, and in accordance with the furnished instructions.

START UP

1. Open the manual gas valve, in the gas supply line to the duct furnace. Loosen the union in the gas supply line to purge it of air. Tighten the union, and check for leaks.

NOTICE: Check all pipe joints for leakage using a soap solution or other approved method.

▲ DANGER Never use an open flame to detect gas leaks. Explosive conditions may exist which could result in property damage, personal injury or death.

▲ WARNING Before attempting to light or relight the pilot, wait 5 minutes to allow gas which may have accumulated in the burner compartment to escape. Failure to heed this warning could result in property damage, personal injury or death!

2. Turn on electrical power. The duct furnace should now be under the control of the thermostat. Set the thermostat to it's highest setting, the power ventor motor should start, and burner ignition occur. Turn the thermostat to the lowest setting. The burners and power ventor should stop operating immediately. Reset the thermostat to the desired operational setting.

PRIMARY AIR SHUTTER ADJUSTMENT

After the unit has been operating for at least 15 minutes, adjust the primary air flow to the burners. Turn the friction-locked, manually-rotated air shutters clockwise to close, and counterclockwise to open.

For correct air adjustment, close the shutter until yellow tips in the flame appear. Then, open the air shutter to the point just beyond where the yellow tipping disappears. Refer to Figure 12.

NOTICE: There may be momentary and spasmodic orange flashes in the flame. This is caused by the burning of airborne dust particles, and should not be confused with yellow tipping, which is a stable, or permanent, situation when there is insufficient primary air.

Figure 12 - Main Burner Flames

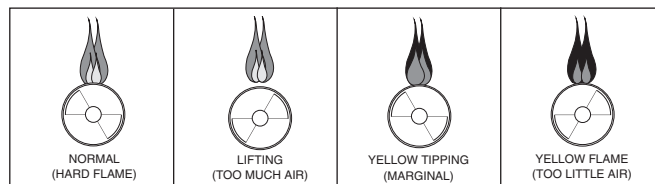

SHUT DOWN

1. Turn the valve selector knob to the "OFF" position.
2. Turn off the electricity.
3. To relight, follow "Initial Lighting" instructions.

MAINTENANCE

PERIODIC SERVICE

▲ WARNING Open all disconnect switches and secure in that position before servicing unit. Failure to do so may result in personal injury or death from electrical shock!

▲ WARNING Gas tightness of the safety shut-off valves must be checked on at least an annual basis.

To check gas tightness of the safety shut-off valves, turn off the manual valve upstream of the appliance combination control. Remove the 1/8 inch pipe plug on the inlet side of the combination control and connect a manometer to that tapping. Turn the manual valve on to apply pressure to the combination control. Note the pressure reading on the manometer, then turn the valve off. A loss of pressure indicates a leak. If a leak is detected, use a soap solution to check all threaded connections. If no leak is found, combination control is faulty and must be replaced before putting appliance back in service.

NOTICE: The heater and vent system should be checked once a year by a qualified technician.

Should maintenance be required, perform the following inspection and service routine:

1. Inspect the area near the unit to be sure that there is no combustible material located within the minimum clearance requirements listed in Table 3.

▲ WARNING Under no circumstances should combustible material be located within the clearances specified in Table 3. Failure to provide proper clearances could result in personal injury or equipment damage from fire!

2. Turn off the manual gas valve and electrical power to the duct furnace.
3. To clean or replace the main burners, open the bottom panel and compress the spring by moving the burner toward the manifold. Slide the opposite end of the burner downward from the locating slot while retaining spring is still compressed. Pull the burners away from the heater.
4. With the burners removed, wire brush the inside surfaces of the heat exchanger.
5. Remove any dirt, dust, or other foreign matter from the burners using a wire brush and/or compressed air. Ensure that all parts are unobstructed. Inspect and clean the pilot burner if necessary.
6. Reassemble the gas duct furnace by replacing all parts in reverse order.
7. Complete the appropriate unit start-up procedure as given in the "Operation" section of this manual (see unit lighting instruction plate and the unit nameplate).
8. Check the burner adjustment. See "Primary Air Shutter Adjustment" section in this manual.
9. Check all gas control valves and pipe connections for leaks.
10. Check the operation of the automatic gas valve by lowering the setting of the thermostat, stopping the operation of the gas duct furnace. The gas valve should close tightly, completely extinguishing the flame on the main burners.
11. Inspect and service the blower section of the system.
12. Check and test the operational functions of all safety devices supplied with your unit.

Figure 13 - Combustion Chamber

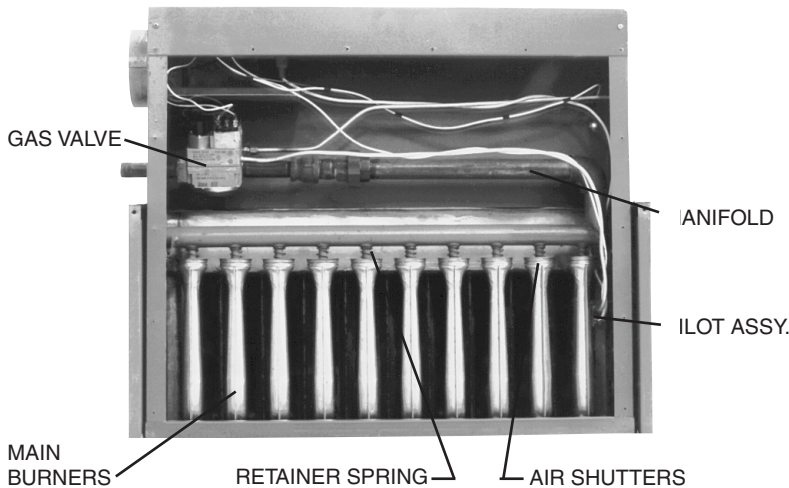

Figure 14 - Internal Furnace Assembly

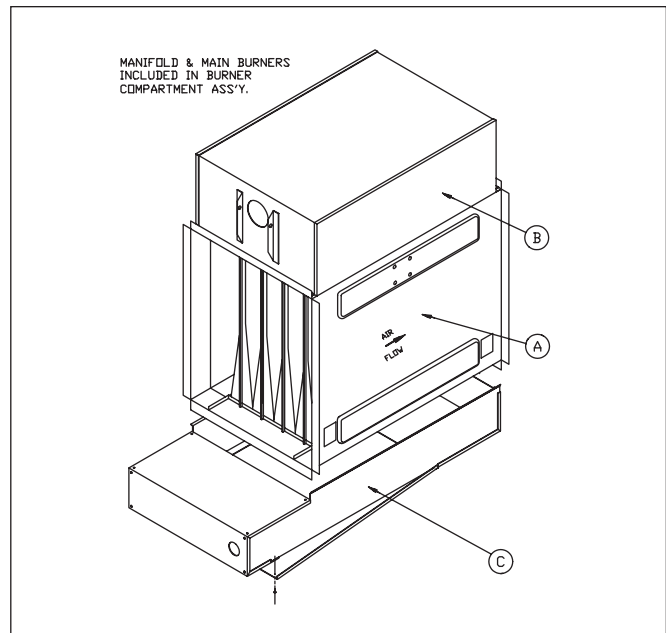
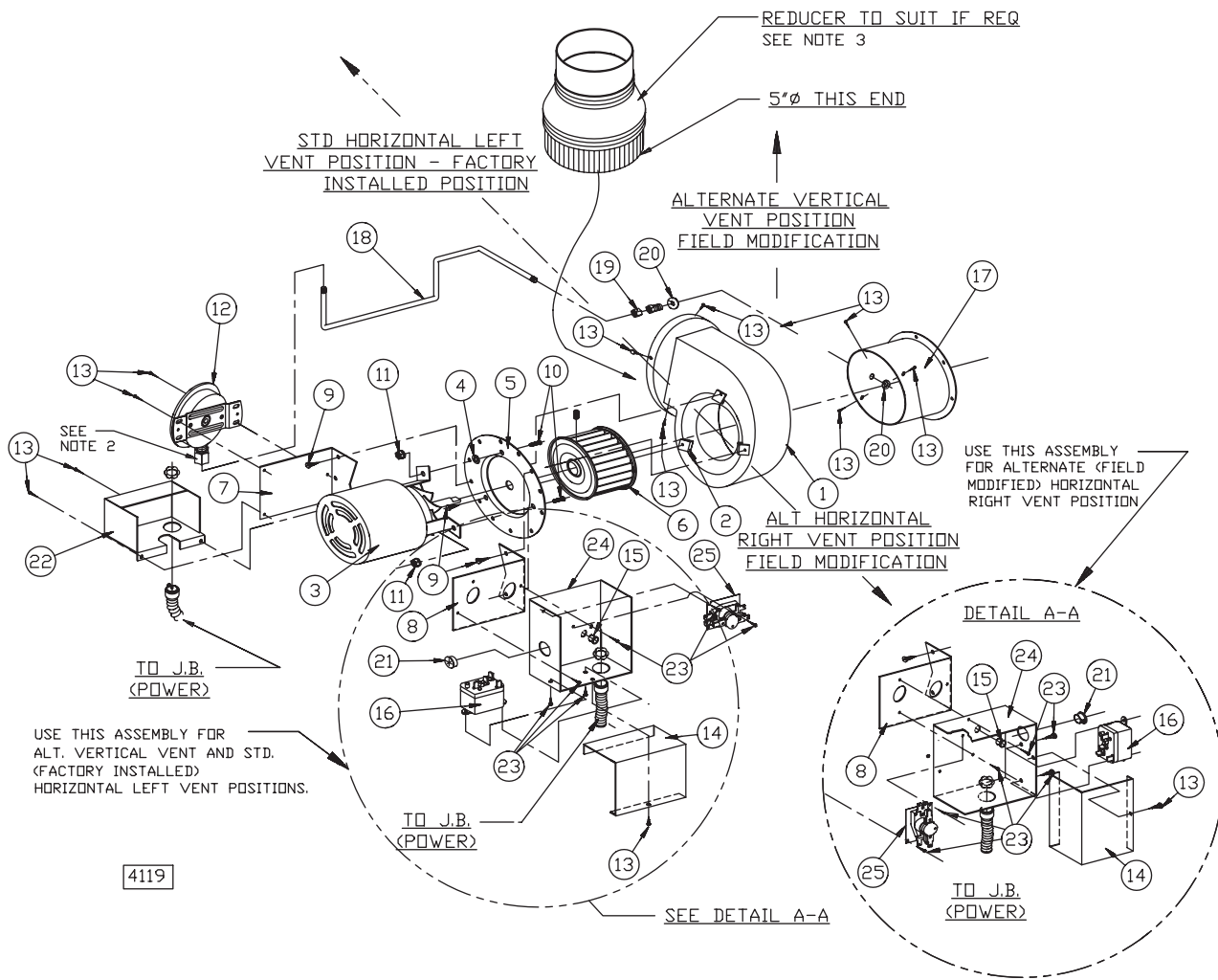

Figure 15 - Power Venter Assembly



Ref. No.	Description	Ref. No.	Description
1	Blower Housing Assembly	14	Junction Box Cover
2	Speed Nut	15	Snap Bushing
3	Motor	16	Relay (Motor)
4	Washer, Plain	17	Draftor Stack Assembly
5	Plate Adapter	18	Tubing (Aluminum) Formation
6	Blower Wheel	19	Male Connector
7	Mounting Bracket (Pressure Switch)	20	Locknut
8	Mounting Bracket (Junction Box)	21	Hole Plug
9	Screw, S.T.	22	Pressure Switch Cover
10	Screw, Machine (L = 3/4 inch)	23	Drill Screw
11	Nut, Keps (Ext. Lock Washer)	24	Junction Box Base
12	Air Pressure Switch*	25	Relay (Purge)
13	Drill Screw		

NOTES:

- *1) For item No. 6 use counter-clockwise rotation.
- 2) **DO NOT OVERTIGHTEN CELCON NUT! HAND TIGHTEN ONLY! DO NOT USE TOOLS!**
Approximate 1/3 turn maximum or 8 inch pounds is sufficient from the point where the tube does not slip in or out.
- 3) Flue Sizes:
100/175 units: 4 inch diameter flue outlet Reducer required – To be supplied by installer.
200/250 units: 5 inch diameter flue outlet (no adaptor required on flue).
300/400 units: 6 inch diameter flue outlet Increaser required – To be supplied by manufacturer.
- 4) See “Power Vent Position” in Installation section for instructions on how to adjust vent position from factory installed position.

Table 9 - Troubleshooting Guide

SYMPTOMS	POSSIBLE CAUSE(S)	CORRECTIVE ACTION
A. Flame lifting from burner ports.	<ol style="list-style-type: none"> 1. Pressure regulator set too high. 2. Defective regulator. 3. Burner orifice too large. 	<ol style="list-style-type: none"> 1. Reset manifold Pressure. Refer to "Operation". 2. Replace regulator section of combination gas valve or complete valve. 3. Check with local gas supplier for proper orifice size, and replace. Refer to "Operation".
B. Flame pops back.	<ol style="list-style-type: none"> 1. Excessive primary air. 2. Burner orifice too small. 	<ol style="list-style-type: none"> 1. Close air shutter. Refer to "Operation". 2. Check with local gas supplier for proper orifice size and replace. Refer to "Operation".
C. Noisy flame.	<ol style="list-style-type: none"> 1. Too much primary air. 2. Noisy pilot. 3. Irregular orifice causing whistle or resonance. 4. Excessive gas input. 	<ol style="list-style-type: none"> 1. Close air shutter. 2. Reduce pilot gas. Refer to "Operation". 3. Replace orifice. 4. Reset manifold pressure. Refer to "Operation": Replace regulator section of combination gas valve or complete valve; or Check with local gas supplier for proper orifice size, and replace. Refer to "Operation".
D. Yellow tip flame (some yellow tipping on propane gas is permissible).	<ol style="list-style-type: none"> 1. Insufficient primary air. 2. Clogged burner ports. 3. Misaligned orifices. 4. Clogged draft hood. 5. Air shutter. 6. Insufficient combustion air. 	<ol style="list-style-type: none"> 1. Open air shutter. Refer to "Operation". 2. Clean main burner ports. 3. Replace manifold assembly. 4. Clean draft hood. 5. Check for dust or lint at air mixer opening and around air shutter. 6. Check for obstruction in combustion air inlet cap and piping. See "Installation".
E. Floating flame.	<ol style="list-style-type: none"> 1. Blocked Venting. 2. Insufficient combustion air. 3. Blocked heat exchanger 4. Air leak into combustion chamber or draft hood. 	<ol style="list-style-type: none"> 1. Clean flue. Refer to "Installation". 2. Check for obstruction in combustion air inlet cap and piping. See "Installation". 3. Clean heater. 4. Determine cause and repair accordingly.
F. Gas odor.	<ol style="list-style-type: none"> 1. Shut off gas immediately. 2. Blocked heat exchanger/venting. 3. Drafts around heater. 4. Negative pressure in building. 5. Blocked draft hood. 	<ol style="list-style-type: none"> 1. Inspect all gas piping and repair. 2. Clean heat exchanger/flue. 3. Eliminate drafts. Refer to "Installation". 4. See "Installation". 5. Clean draft hood.

Table 9 - Troubleshooting Guide

SYMPTOMS	POSSIBLE CAUSE(S)	CORRECTIVE ACTION
G. Delayed ignition.	<ol style="list-style-type: none"> 1. Excessive primary air. 2. Main burner ports clogged near pilot. 3. Pressure regulator set too low. 4. Pilot decreases in size when main burners come on. 5. Pilot flame too small. 6. Drafts around ventor. 7. Improper venting. 	<ol style="list-style-type: none"> 1. Close air shutter. Refer to "Operation". 2. Clean main burner ports. 3. Reset manifold pressure. Refer to "Operation". 4. Supply piping is inadequately sized. Refer to "Installation". 5. Clean pilot orifice. Refer to "Operation". 6. Eliminate drafts. Refer to "Installation". 7. Refer to "Installation".
H. Failure to ignite.	<ol style="list-style-type: none"> 1. Main gas valve off. 2. Lack of power at unit. 3. Thermostat not calling for heat. 4. Defective limit switch. 5. Improper thermostat or transformer wiring at gas valve. 6. Defective gas valve. 7. Defective thermostat. 8. Defective transformer. 9. Loose wiring. 10. Defective ignition control. 	<ol style="list-style-type: none"> 1. Open all manual gas valves. 2. Replace fuse or turn on power supply. 3. Turn up thermostat. 4. Check limit switch with continuity tester. If open, replace high limit. 5. Check wiring per wiring diagrams. 6. Replace gas valve. 7. Check thermostat and replace if defective. 8. Be sure 115 volts is supplied to the transformer primary, then check for 24 volts at secondary terminal before replacing. 9. Check and tighten all wiring connections per diagrams. 10. Replace, if necessary. Also see W, X, & Y symptoms.
J. Condensation of water vapor.	<ol style="list-style-type: none"> 1. Condensation of water vapor. 	<ol style="list-style-type: none"> 1. Refer to "Installation, Venting".
K. Burner won't turn off.	<ol style="list-style-type: none"> 1. Poor thermostat location. 2. Defective thermostat. 3. Improper thermostat or transformer wiring at gas valve. 4. Short circuit. 5. Defective or sticking gas valve. 6. Excessive gas supply pressure. 	<ol style="list-style-type: none"> 1. Relocate thermostat away from drafts. 2. Replace thermostat. 3. Check wiring diagrams. 4. Check operation at valve. Look for short (such as staples piercing thermostat wiring) and correct. 5. Replace gas valve. 6. Refer to "Operation".

Table 9 - Troubleshooting Guide

SYMPTOMS	POSSIBLE CAUSE(S)	CORRECTIVE ACTION
L. Rapid burner cycling.	<ol style="list-style-type: none"> 1. Loose wire connections at gas valve or thermostat. 2. Excessive thermostat heat anticipator. 3. Unit cycling on high limit. 4. Poor thermostat location. 5. Draft on pilot. 6. Defective ignitor control. 7. Defective high limit. 	<ol style="list-style-type: none"> 1. Tighten all connections. 2. Adjust thermostat for longer cycles. Refer to "Operation". 3. Check for proper air supply across heat exchanger. 4. Relocate thermostat (do not mount thermostat on unit). 5. Eliminate drafts. Refer to "Installation". 6. Replace ignitor. 7. Jumper high limit switch terminals 1 and 2. If burner operates normally, replace switch.
M. Noisy power ventor.	<ol style="list-style-type: none"> 1. Power ventor wheel loose. 2. Power ventor wheel dirty. 3. Power ventor wheel rubbing housing. 4. Bearings are dry. 	<ol style="list-style-type: none"> 1. Replace or tighten. 2. Clean power ventor wheel. 3. Realign power ventor wheel. 4. Oil bearings on power ventor motor. Refer to label on motor.
N. Pilot will not light or will not stay lit.	<ol style="list-style-type: none"> 1. Main gas valve off. 2. Pilot adjustment screw turned too low on combination main gas valve. 3. Air in gas line. 4. Incorrect lighting procedure. 5. Dirt in pilot orifice. 6. Extremely high or low gas pressure. 7. Drafts around unit. 8. Pilot valve not opening (faulty wiring). 9. No spark (faulty wiring). 10. Defective gas valve. 	<ol style="list-style-type: none"> 1. Open all manual gas valves. 2. Refer to "Operation". 3. Purge air from gas line. 4. Follow lighting instruction label adjacent to gas valve. 5. Remove pilot orifice. Clean with compressed air or solvent. Do not ream. 6. Refer to "Operation". 7. Eliminate drafts. Refer to "Installation". 8. Inspect and correct wiring. 9. Inspect and correct ignition system wiring. See symptoms W, X & Y. 10. Replace gas valve.

Table 9 - Troubleshooting Guide

SYMPTOMS	POSSIBLE CAUSE(S)	CORRECTIVE ACTION
O. Power ventor will not run.	<ol style="list-style-type: none"> 1. Loose wiring. 2. Defective motor overload protector or defective motor. 3. Defective power ventor relay. 	<ol style="list-style-type: none"> 1. Check and tighten all wiring connections per diagrams. Thermostat wires tagged "W" and "G" must be connected together (unless special thermostats are used; if so, see thermostat wiring diagram). See "Electrical Connections". 2. Replace motor. 3. Check 24V across 1 and 3 terminals on fan relay. If 24V is present, jumper terminals numbered 2 and 4. If motor runs, the relay is defective and must be replaced. If 24V is not present, check wiring per wiring diagrams.
P. Power ventor motor turns on and off while burners are operating.	<ol style="list-style-type: none"> 1. Fan relay heater element improperly wired. 2. Defective ventor relay switch. 3. Motor protector cycling on and off. 4. Motor not properly oiled. 	<ol style="list-style-type: none"> 1. Be sure ventor relay heater terminals are connected per diagrams. 2. Replace ventor motor. 3. Check motor amps against motor name plate rating, check voltage, replace power ventor motor if defective. 4. Refer to label on motor.
Q. Power ventor motor will not stop.	<ol style="list-style-type: none"> 1. Improperly wired ventor relay. 2. Main burners not lighting while thermostat calls for heat. 3. Defective ventor relay. 	<ol style="list-style-type: none"> 1. Check all wiring. 2. Refer to H & N Symptoms. 3. Replace ventor relay.
R. Not enough heat.	<ol style="list-style-type: none"> 1. Incorrect gas input. 2. Heater undersized. 3. Thermostat malfunction. 4. Heater cycling on high limit. 5. Check outside dampers if used. 	<ol style="list-style-type: none"> 1. Refer to "Operation". 2. This is especially true when heated space is enlarged. Have heat loss calculated and compare to heater output (80% of input). Your gas supplier or installer can furnish this information. If heater is undersized, add additional heaters. 3. Replace thermostat. 4. Check air movement through heat exchanger. Check voltage to fan motor. Clean power ventor motor. 5. Adjust dampers accordingly.
T. Too much heat.	<ol style="list-style-type: none"> 1. Thermostat malfunction. 2. Heater runs continuously. 	<ol style="list-style-type: none"> 1. Replace thermostat. 2. Check wiring diagrams; Check operation at valve. Look for short (such as staples piercing thermostat wiring) and correct: Replace gas valve; Refer to "Operation".
U. Cold air is delivered on start-up	<ol style="list-style-type: none"> 1. Fan relay heater element improperly wired. 	<ol style="list-style-type: none"> 1. Be sure fan relay heater terminal are connected per diagrams.

Table 9 - Troubleshooting Guide

SYMPTOMS	POSSIBLE CAUSE(S)	CORRECTIVE ACTION
V. Cold air is delivered during heater operation.	<ol style="list-style-type: none"> 1. Incorrect manifold pressure or input. 2. Voltage to unit too high. 3. Air through put too high. 	<ol style="list-style-type: none"> 1. Refer to "Operation". 2. Check motor voltage with fan running. Should be 115 volts AC. 3. Refer to "Operation".
W. No spark.	<ol style="list-style-type: none"> 1. Thermostat not calling for heat. 2. No low voltage. 3. Spark gap closed or too wide. 4. Broken or cracked ceramic on spark electrode. 	<ol style="list-style-type: none"> 1. Close thermostat contacts. 2. Check for 24V across 24V terminals of S8600. 3. Set gap to 0.1". 4. Replace pilot assembly.
X. Spark present but pilot does not light.	<ol style="list-style-type: none"> 1. Loose S8600 connections. 2. Improper gas pressure. 3. Is spark in pilot gas stream? 4. No pilot gas — do not use match to test - presence of gas is easily detected by the odor. 	<ol style="list-style-type: none"> 1. Check all connections, term. PV feeds 24V to pilot valve. 2. Check pressure — pressure that is either too high or too low may cause a problem. 3. Spark should arc from electrode. 4. Check pilot line for kinks. Ensure there are no drafts.
Y. Pilot lights — Main valve does not energize.	<ol style="list-style-type: none"> 1. Loose S8600 connections. 2. Cracked or broken sensor ceramic. 3. Check sensor/spark lead for continuity. 4. Measure 24 volts from term. MV to term. MV/PV. 	<ol style="list-style-type: none"> 1. Check connections-term. MV feeds main valve. 2. Replace pilot assembly. 3. Replace if needed. 4. If present, replace main valve; if not, replace S8600 Igniter.
Z. Hi-Limit switch tripping.	<ol style="list-style-type: none"> 1. Unit is overfiring. 2. Air flow too low 3. Defective switch. 	<ol style="list-style-type: none"> 1. Manifold pressure too high; adjust. Burner orifices may be too large: verify/replace if req'd. 2. Increase air flow; check fan size. Check for proper voltage. 3. Replace.

HOW TO ORDER REPLACEMENT PARTS

Please send the following information to your local representative; If further assistance is needed, contact the manufacturer's customer service department.

- Unit number
- Serial Number (if any)
- Part description and Number as shown in the Replacement Parts Catalog.

LIMITED WARRANTY

SEPARATED COMBUSTION DUCT FURNACE

1. The "Manufacturer" warrants to the original owner at original installation site that our Separated Combustion Duct Furnace ("the Product") will be free from defects in material or workmanship for one (1) year from the date of shipment from the factory. If upon examination by the Manufacturer the Product is shown to have a defect in material or workmanship during the warranty period, the Manufacturer will repair or replace, at its option, that part of the Product which is shown to be defective.
2. This limited warranty does not apply:
 - (a) if the Product has been subjected to misuse or neglect, has been accidentally or intentionally damaged, has not been installed, maintained or operated in accordance with the furnished written instructions, or has been altered or modified in any way by any unauthorized person.
 - (b) to any expenses, including labor or material, incurred during removal or reinstallation of the Product.
 - (c) to any damage due to corrosion by chemicals, including halogenated hydrocarbons, precipitated in the air.
 - (d) to any workmanship of the installer of the Product.
3. This limited warranty is conditional upon:
 - (a) advising the installing contractor, who will in turn notify the distributor or manufacturer.
 - (b) shipment to the Manufacturer of that part of the Product thought to be defective . Goods can only be returned with prior written approval of the Manufacturer. All returns must be freight prepaid.
 - (c) determination in the reasonable opinion of the Manufacturer that there exists a defect in material or workmanship.
4. Repair or replacement of any part under this Limited Warranty shall not extend the duration of the warranty with respect to such repaired or replaced part beyond the stated warranty period.
5. **THIS LIMITED WARRANTY IS IN LIEU OF ALL OTHER WARRANTIES, EITHER EXPRESS OR IMPLIED, AND ALL SUCH OTHER WARRANTIES, INCLUDING WITHOUT LIMITATION IMPLIED WARRANTIES OF MERCHANTABILITY OR FITNESS FOR A PARTICULAR PURPOSE, ARE HEREBY DISCLAIMED AND EXCLUDED FROM THIS LIMITED WARRANTY. IN NO EVENT SHALL THE MANUFACTURER BE LIABLE IN ANY WAY FOR ANY CONSEQUENTIAL, SPECIAL, OR INCIDENTAL DAMAGES OF ANY NATURE WHATSOEVER, OR FOR ANY AMOUNTS IN EXCESS OF THE SELLING PRICE OF THE PRODUCT OR ANY PARTS THEREOF FOUND TO BE DEFECTIVE. THIS LIMITED WARRANTY GIVES THE ORIGINAL OWNER OF THE PRODUCT SPECIFIC LEGAL RIGHTS. YOU MAY ALSO HAVE OTHER RIGHTS WHICH MAY VARY BY EACH JURISDICTION.**

In the interest of product improvement, we reserve the right to make changes without notice.

SEPARATED COMBUSTION INDOOR DUCT FURNACE UNIT NUMBER DESCRIPTION

Digit	X	X	X	X	1	2	3	4	5	6	7	8	9	10	11	12	13	14	15	+	
Item	Prefix				UT	CA			FT	FM	GT	IC	AL	GC	SV	MT	MS	AS			

(Internal use Only)

Digit #1, 2 - Unit Type [UT]
D6 - Separated Combustion Duct Furnace

Digit #3, 4, 5 - Capacity [CA]
100 - 100,000 BTU/HR
125 - 125,000 BTU/HR
150 - 150,000 BTU/HR
175 - 175,000 BTU/HR
200 - 200,000 BTU/HR
225 - 225,000 BTU/HR
250 - 250,000 BTU/HR
300 - 300,000 BTU/HR
350 - 350,000 BTU/HR
400 - 400,000 BTU/HR

Digit #6 - Furnace Type [FT]
A - Right Side Access (Optional)
B - Left Side Access (Standard)

Digit #7 - Heat Exchanger Construction Material [FM]
1 - Aluminized Steel
2 - 409 Stainless Steel
3 - 321 Stainless Steel

Digit #8 - Gas Type [GT]
N - Natural Gas
P - Propane Gas (LP)
K - Natural Gas w/100% Shutoff

Digit #9 - Ignition Control [IC]
2 - Spark Ignition

Digit #10 - Altitude [AL]
A - 0-1,999 ft. J - 8,000-8,999 ft.
B - 2,000-2,999 ft. K - 9,000-9,999 ft.
C - 3,000-3,999 ft. L - 10,000-10,999 ft.
D - 4,000-4,999 ft. M - 11,000-11,999 ft.
F - 5,000-5,999 ft. N - Local Gas Supplier Derate
G - 6,000-6,999 ft. P - Canadian High Altitude 2,000-4,500 ft.
H - 7,000-7,999 ft.

Digit #11 - Gas Control [GC]
A - Single Stage
B - Two Stage
H - Electronic Modulation w/Room Sensing
J - Electronic Modulation w/Duct Sensing
K - Electronic Modulation w/Duct Sensing & Room Ovrd. Stat
L - Electronic Modulation w/External 4-20 mA Input
N - Electronic Modulation w/External 0-10 VDC Input

Digit #12 - Supply Voltage [SV]
1 - 115/1/60 5 - 230/3/60
2 - 208/1/60 6 - 460/3/60
3 - 230/1/60 7 - 575/3/60
4 - 208/3/60 Z - Special

Note: Supply Voltages [SV] 2-7 include field mounted step down transformer.

Digit #13 - Motor Type [MT]
0 - None/Not Applicable

Digit #14 - Motor Sizes [MS]
0 - None/Not Applicable

Digit #15 - Accessories [AS]

FACTORY INSTALLED

A8 - Input Derate
K4 - Fan Time Delay
K5 - Air Flow Prove Switch

P4 - Terminal Block Wiring
P6 - Summer/Winter Switch

S1 - 409 Stainless Steel Burners
S3 - 409 Stainless Steel Flue Collector

† FIELD INSTALLED (AS-_____)

† Field Installed Accessories are not included in the Unit Number. All Field Installed Accessories are entered as a separate line item using the catalog number which utilizes "AS" as a prefix. i.e: A7 becomes AS-A7.

A7 - High Pressure Regulator
A7-1/2-1 - Regulator for 0.5-10 PSI
A7-3/8-1 - Regulator for 10-20 PSI
A7-5/16-1 - Regulator for 20-35 PSI

H5 - Low Ambient Control

M2-1 - Vent Caps (4 inch) (Unit Capacity 100-175)
M2-2 - Vent Caps (5 inch) (Unit Capacity 200-250)
M2-3 - Vent Caps (6 inch) (Unit Capacity 300-400)
M3-1 - Adaptors (5-4 inch) (Unit Capacity 100-175)
M4 - Vertical Combustion Air Inlet Kit
M5 - Horizontal Combustion Air Inlet Kit

F1 - 1-Stage T675A Ductstat
F2 - 2-Stage T678A Ductstat

G1 - 1-Stage T87K Mercury Free Thermostat w/Subbase Kit
G2 - 1-Stage T87K Mercury Free Thermostat w/TG511A Guard Kit
G3 - 1-Stage T834N Mercury Free Thermostat w/Fan Switch
G6 - Locking Thermostat Cover
G9 - 1-Stage T822K Mercury Free Thermostat

P2 - Adjustable High Limit Switch
P3 - Adjustable Fan Switch
P5 - 24V SPST Relay-Specify Purpose
Q7 - Horizontal/Vertical Louvers

GAS EQUIPMENT START-UP

Customer _____ Job Name & Number _____

PRE-INSPECTION INFORMATION

With power and gas off.

Type of Equip: Duct Furnace

Serial Number _____ Model Number _____

Name Plate Voltage: _____ Name Plate Amperage: _____

Type of Gas: Natural LP Tank Capacity _____ lbs Rating: _____ BTU @ _____ °F
_____ kg _____ kw @ _____ °C

- Are all panels, doors, vent caps in place?
- Has the unit suffered any external damage? Damage _____
- Does the gas piping and electric wiring appear to be installed in a professional manner?
- Has the gas and electric been inspected by the local authority having jurisdiction?
- Is the gas supply properly sized for the equipment?
- Were the installation instructions followed when the equipment was installed?
- Have all field installed controls been installed?
- Do you understand all the controls on this equipment? *If not, contact your wholesaler or rep.*
(DO NOT START this equipment unless you fully understand the controls.)

GENERAL

With power and gas off.

- Make certain all packing has been removed.
- Tighten all electrical terminals and connections.
- Check all controls for proper settings.

GAS HEATING

With power and gas on.

- Inlet gas pressure. _____ in. WC or _____ kPa
- Pilot & main burner ignition.
- Manifold gas pressure. _____ in. WC or _____ kPa
- Check electronic modulation. Set at: _____
- Cycle and check all other controls not listed.
- Entering air temp. _____ °F or _____ °C
- Discharge air temp. (high fire) _____ °F or _____ °C
- External static pressure _____ in. WC
- Cycle by thermostat or operating control.
- Combustion Reading:
 - Carbon Monoxide: _____ PPM
 - Carbon Dioxide: _____ %

Remarks: _____
